

**Automatic Control of Physiological Function  
for Medical Treatment**

**Control of Brain Temperature**

**Biophysical System Engineering**  
**Graduate School of Allied Health Sciences**  
**Tokyo Medical and Dental University**

**Prof. Dr. H. Wakamatsu**

# **Patient Confronting Death**

**Emergency, in and after Operation**

**( Unconsciousness Comatose State )**

**Brain contusion**

**Ischemia disorder**

**Serious respiratory illness**

**Control of**

**Intracranial Pressure, Respiration,  
Circulation, Anesthesia, Body temperature**

# **Automatic control of patient's state**

**Emergency lifesaving**

**Automatic control of medical equipment**

Respiratory-circulatory assist,  
oxygen inhalation, cough remedy

**Intracranial : Osmotic pressure**

Intracranial osmotic control

**CO<sub>2</sub>, O<sub>2</sub>-concentration : Respiration**

Control of respiratory system

**Brain hypothermia : Body temperature**

Control of circulatory system

**Anesthesia : Physiological state**

Control by respiratory-circulatory system

# **Control of Intracranial Osmotic Pressure**

**by administration of mannitol**

**(Biokinetic and chemical process)**

**Related to ‘Brain Temperature’**

# Schematic Representation of Brain

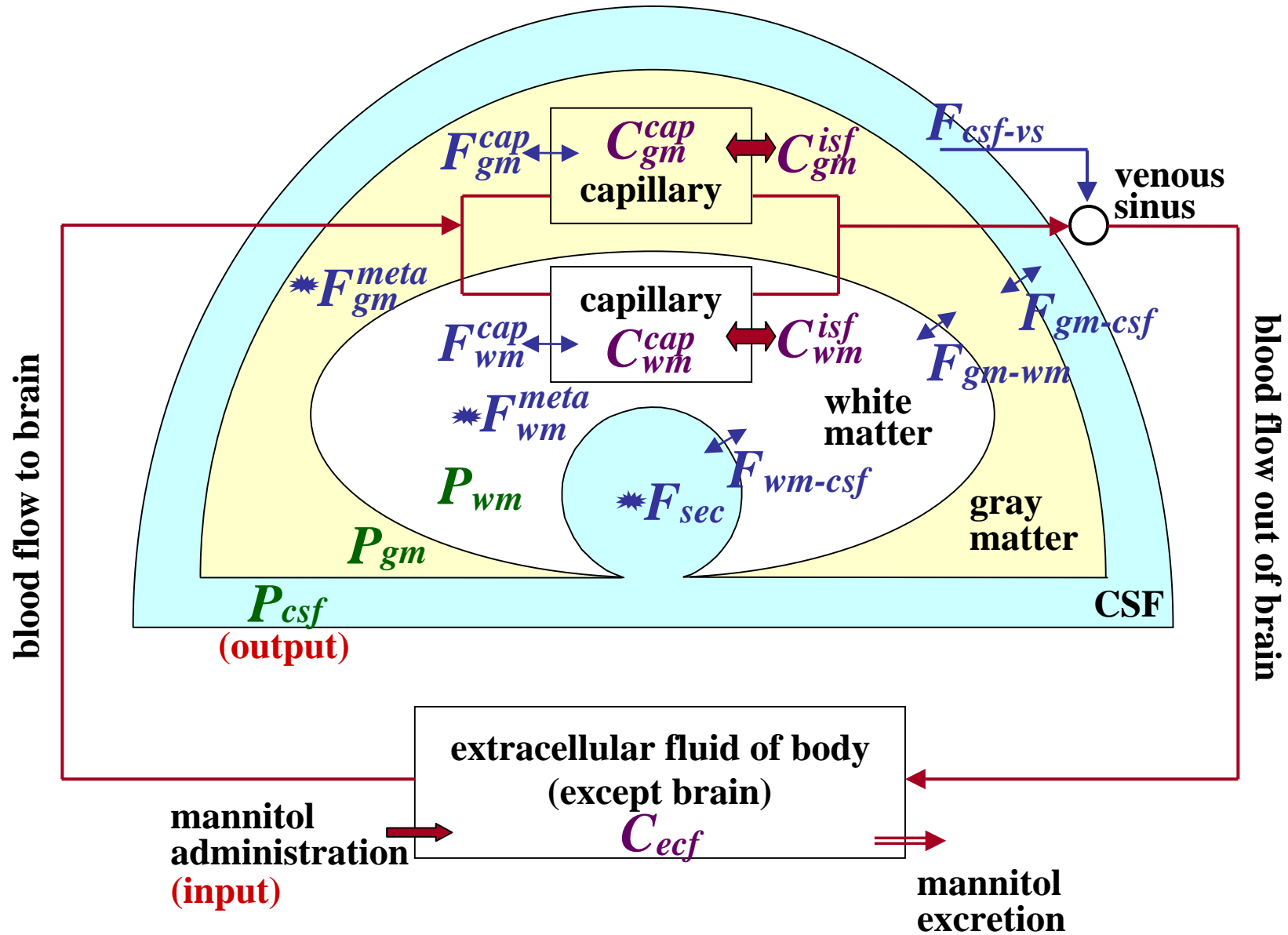

# Intracranial Osmotic Pressure by Different Control Methods

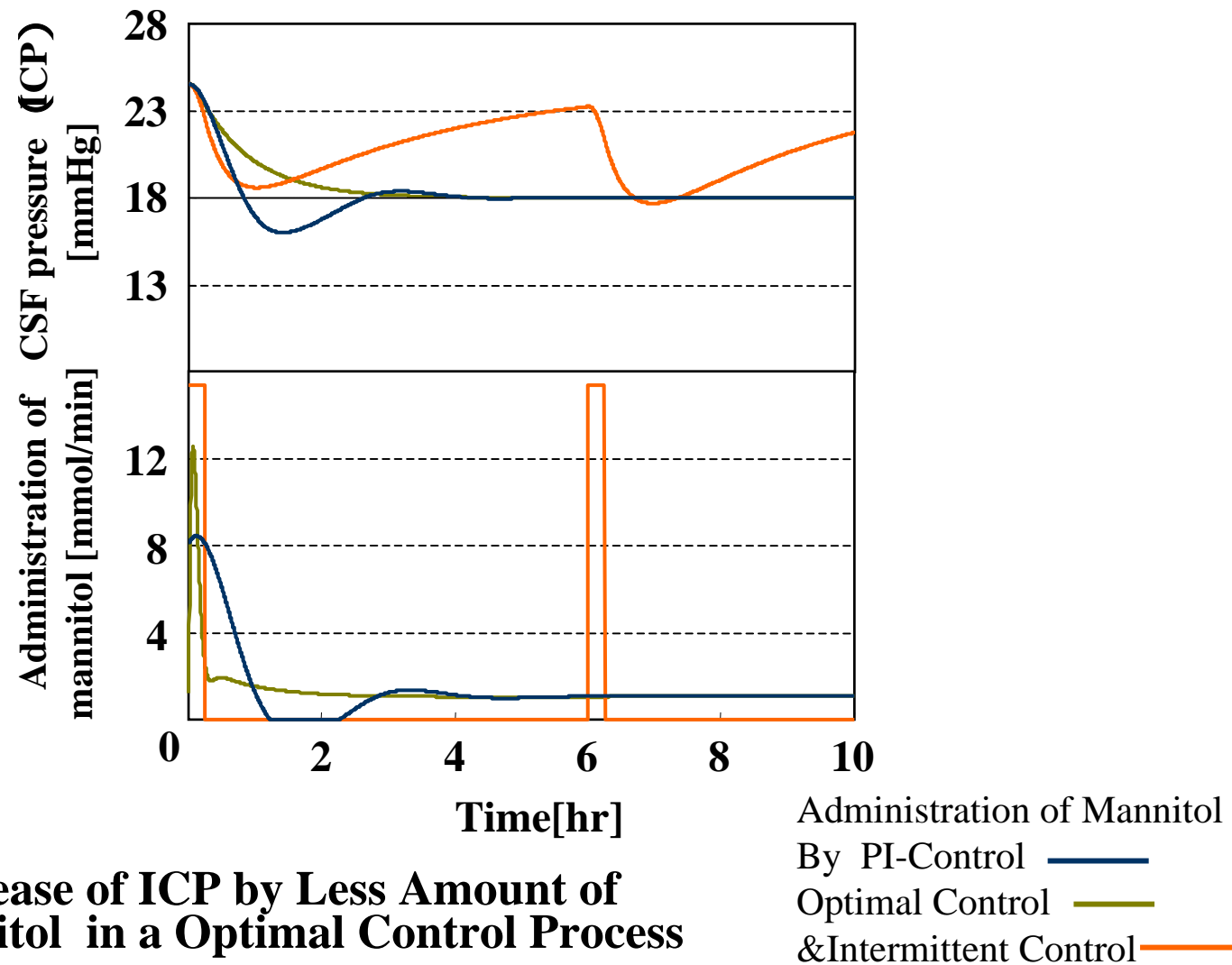

**Decrease of ICP by Less Amount of  
Mannitol in a Optimal Control Process**

# Control of Anesthesia & Respiration

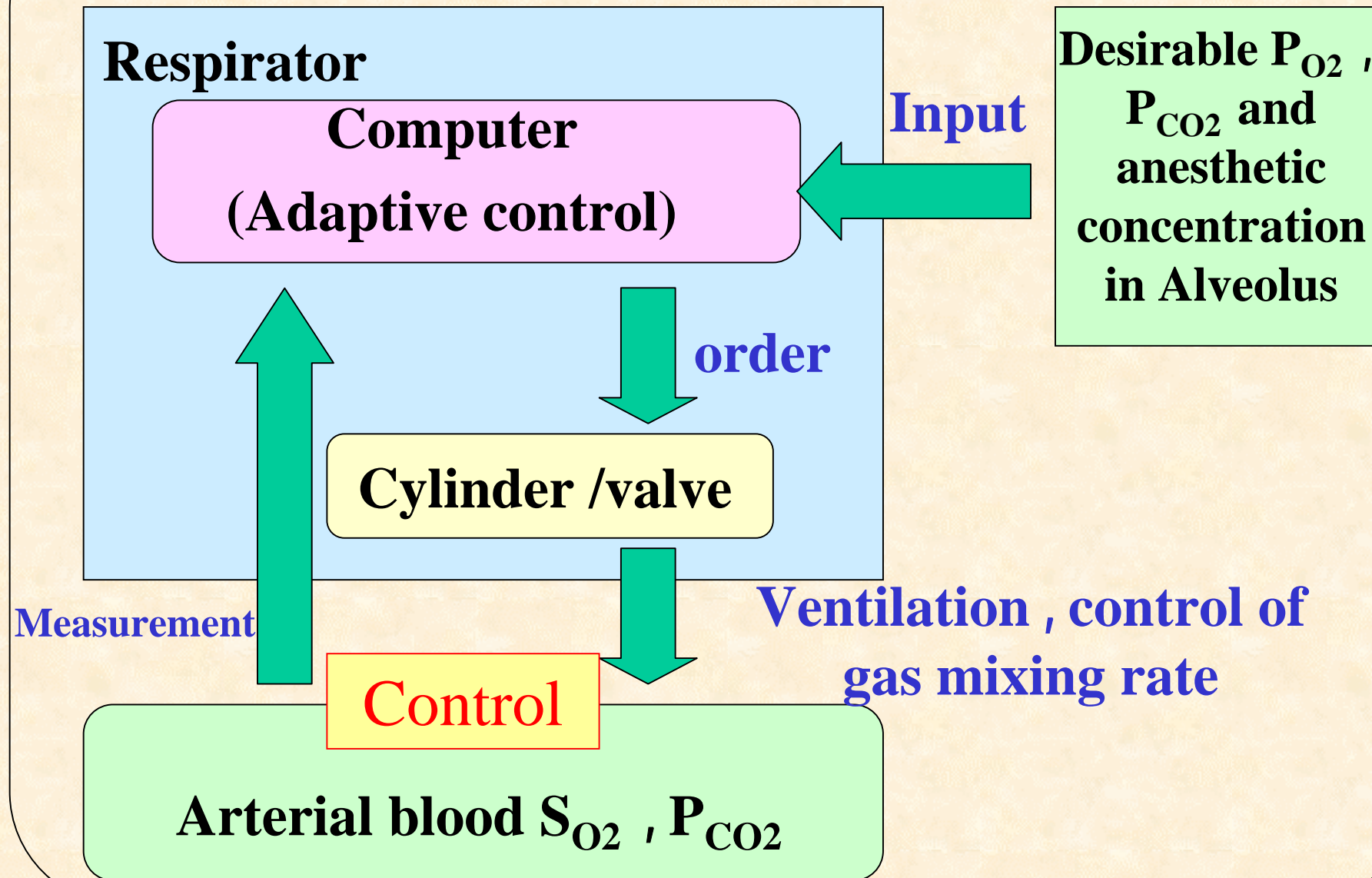

# Respiratory Automatic Control System

**Noninvasive Method**

**Control of Alveolar CO<sub>2</sub>**

**Improvement of hypoxia**

Adaptive Control/ Fuzzy Control

# Mechanical respirator

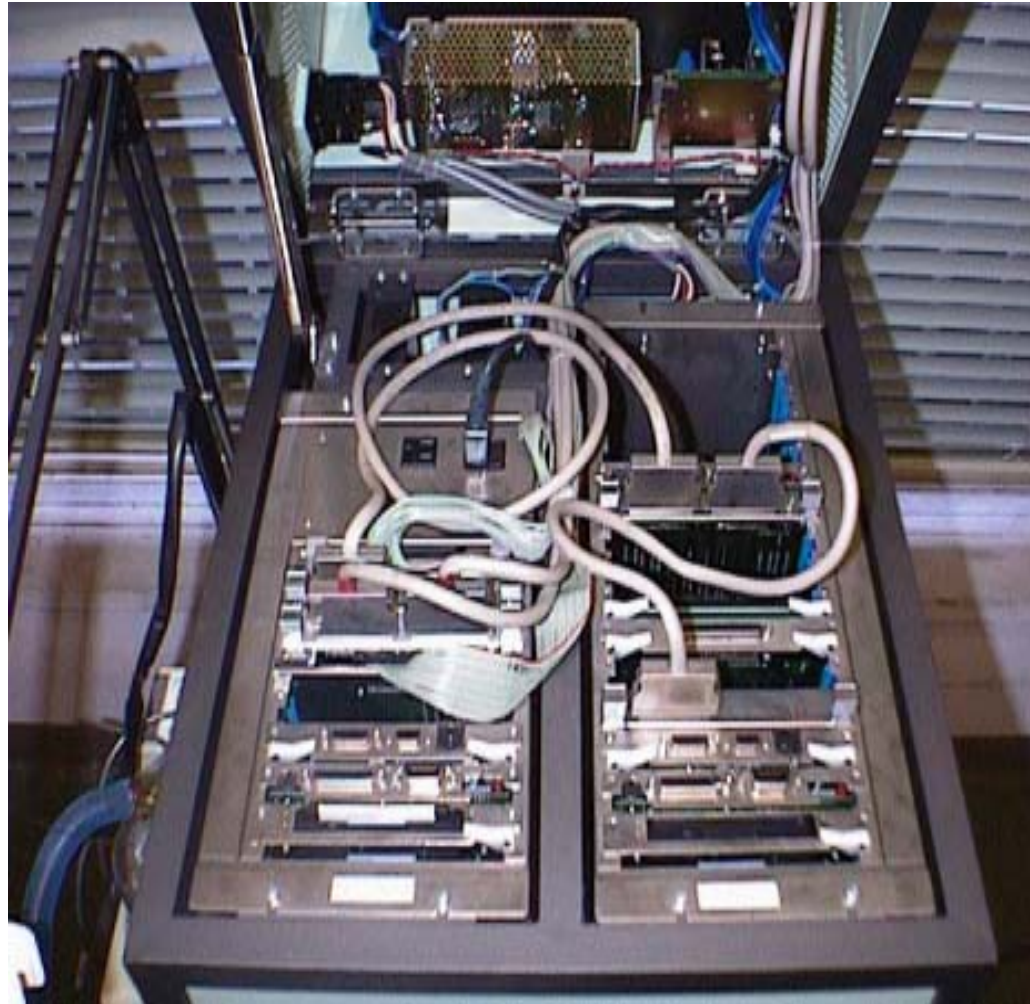

# Adaptive Pole placement system

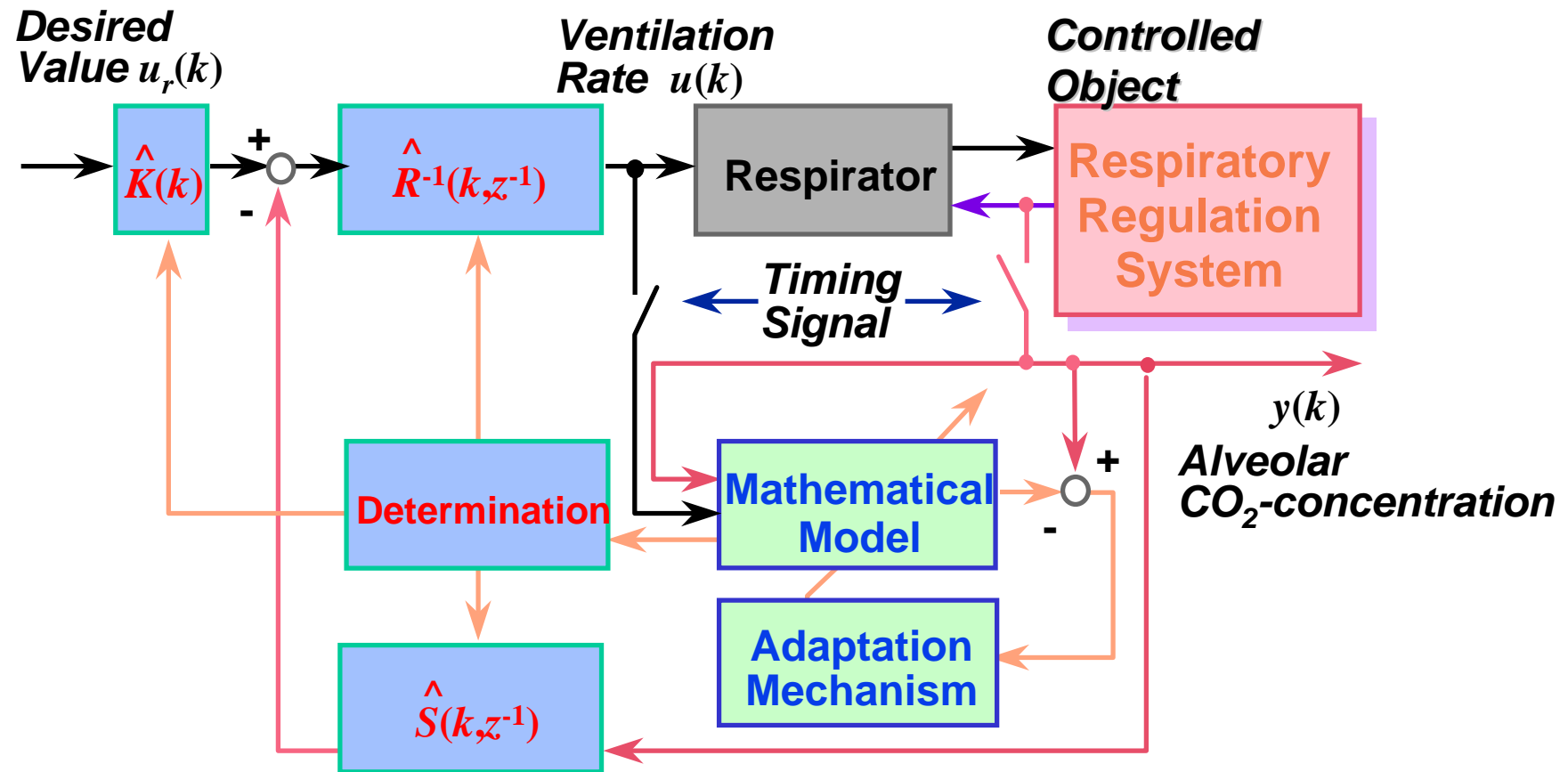

# Controlled respiration

Examp. 1

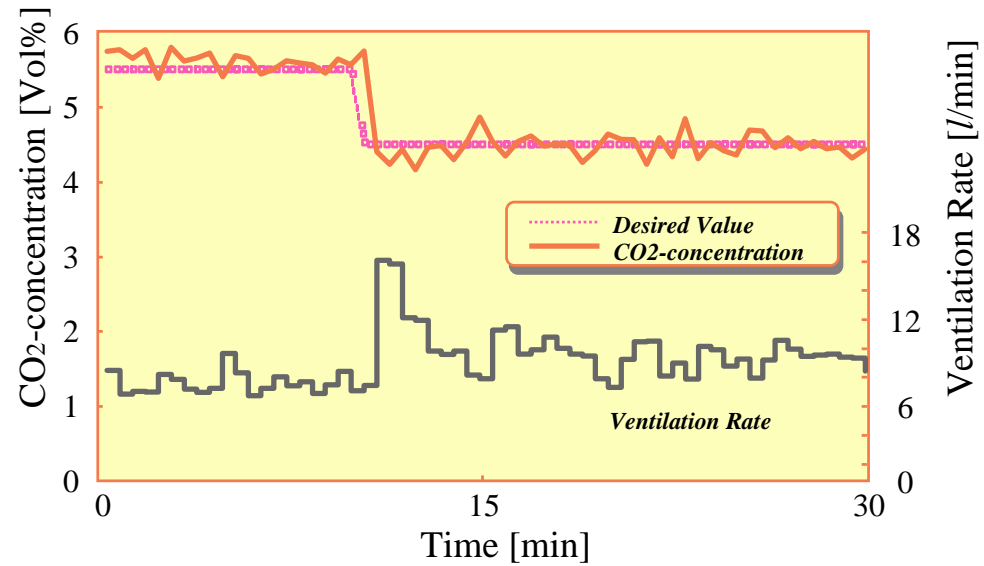

Examp. 2

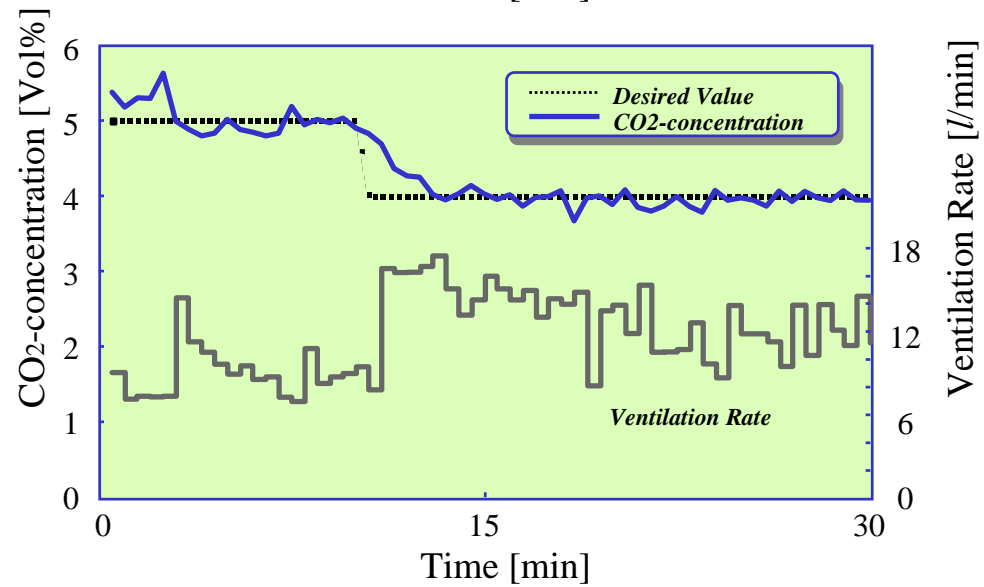

Sampling period 30sec  
(constant)  
ventilatory frequency  
14/min

# Fuzzy control system with respect to difference of individuals

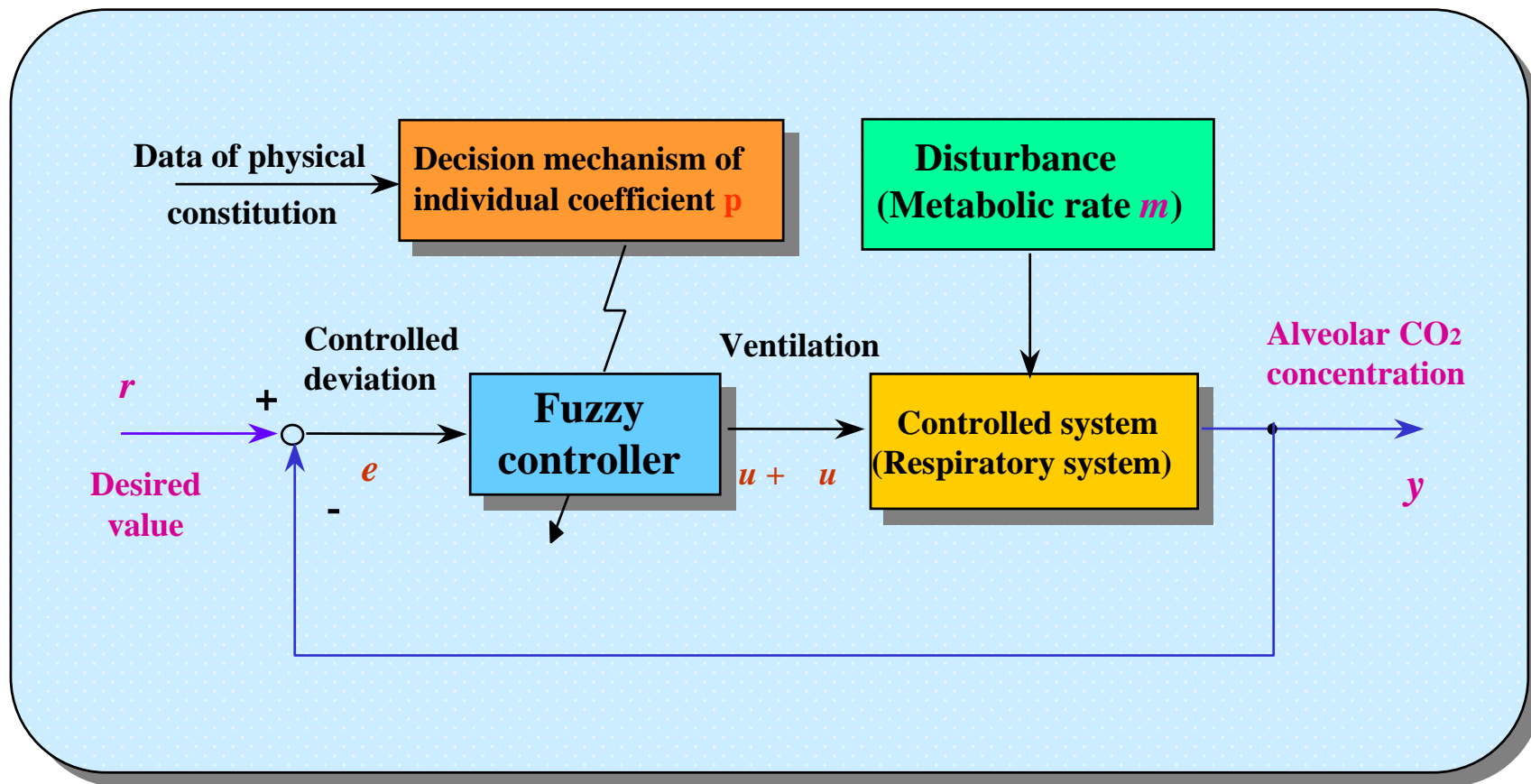

# Fuzzy control with different constitutional coefficients

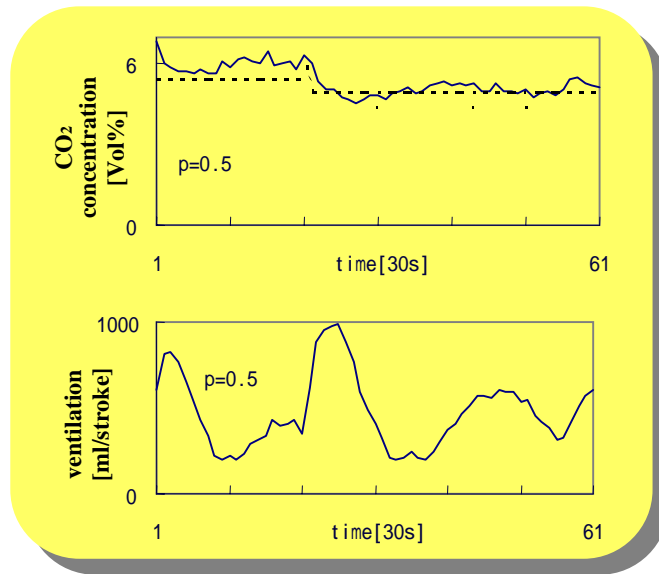

(a)  $p=0.5$

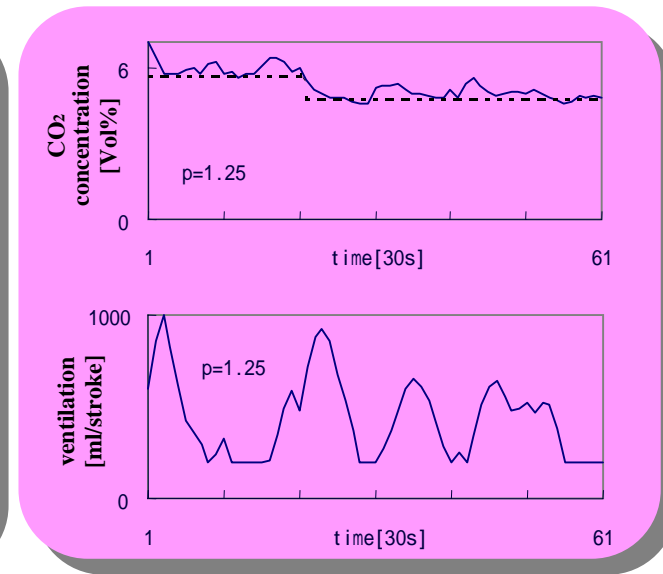

(c)  $p=1.25$

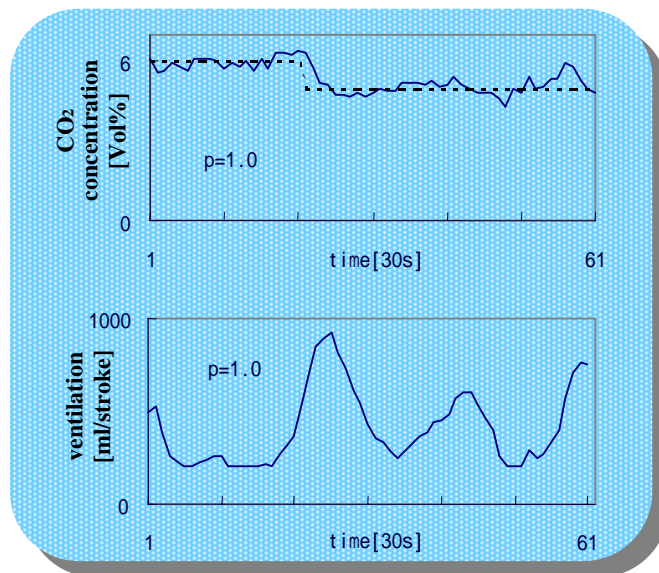

(b)  $p=1.0$

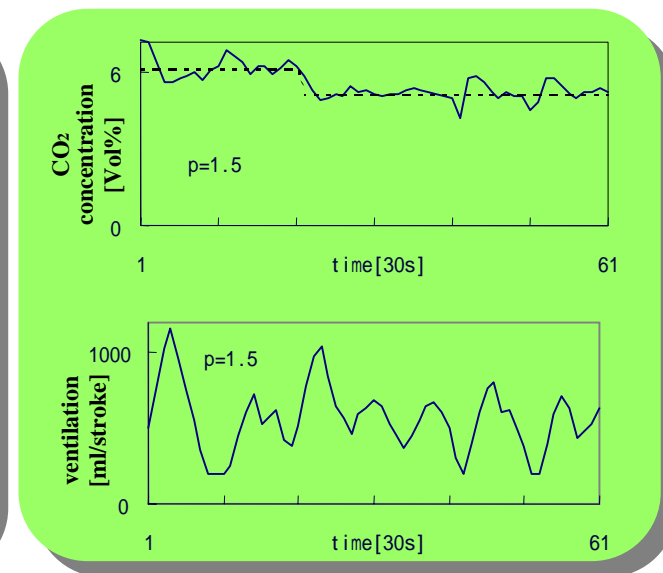

(d)  $p=1.5$

# Administration system of depth of anesthesia

**in expectation of existence of biochemical  
material as an indicator of depth of anesthesia**

**Control of depth of anesthesia by respiration and  
circulation**

**Controlled system : plural subsystems**

**ventilation, gas exchange, circulation, nervous system**

# Comprehensive Monitoring System of Physiological State

**Final Decision and Treatment**



**Anesthesiologist**

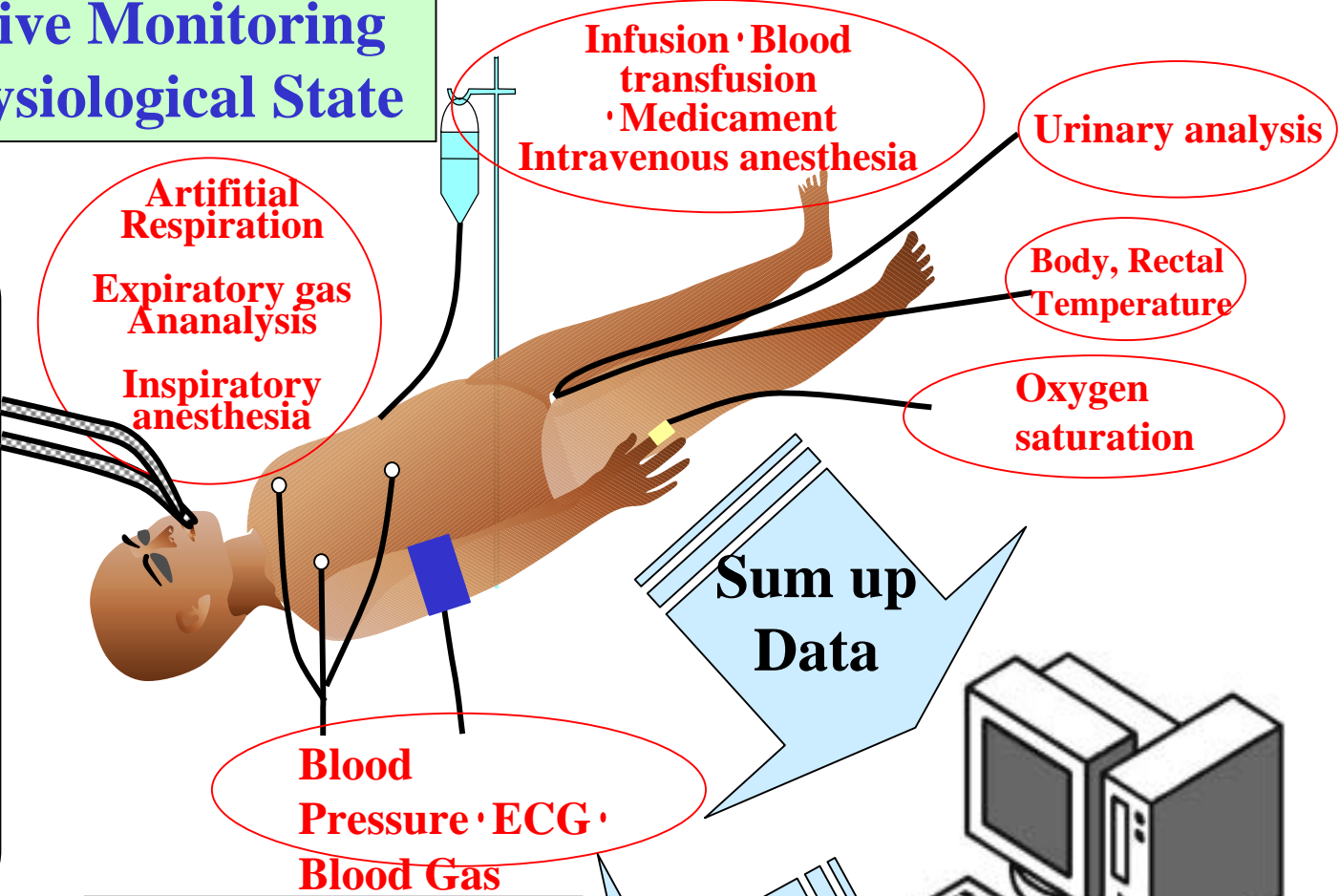

**Sum up Data**

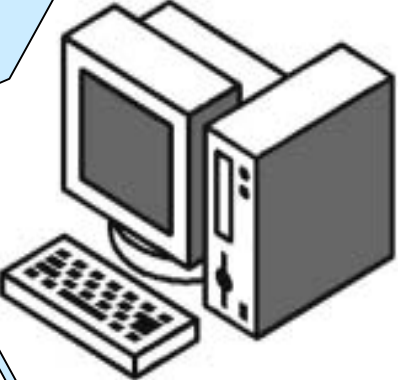

**Inference, Decision, Description**

**Indication by Simple Expression**

**Physiological State**

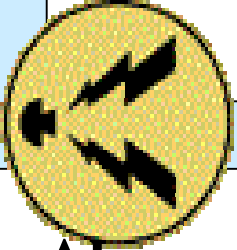

**Alarm**

# Automatic control system for brain temperature

## Control by body surface cooling

- **Noninvasive** measurement and control
- Whole body, cervix and head cooling

**Adaptive control/ Fuzzy control**

# Hypothermia Protection of Brain Tissue

Treatment in the acute stage of irreversible brain damage  
Cooling brain for the protection of its secondary damage

## Surface cooling method

Wash out metabolic heat of brain by cooled  
blood flow supplied from the circulation

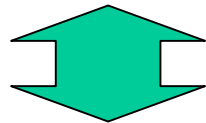

### Dilemma by surface cooling

Constitutional effects caused by  
biochemical environment  
Seriously physiological invasion



Blanket Patient

# Measurement of Temperature in Hypothermia

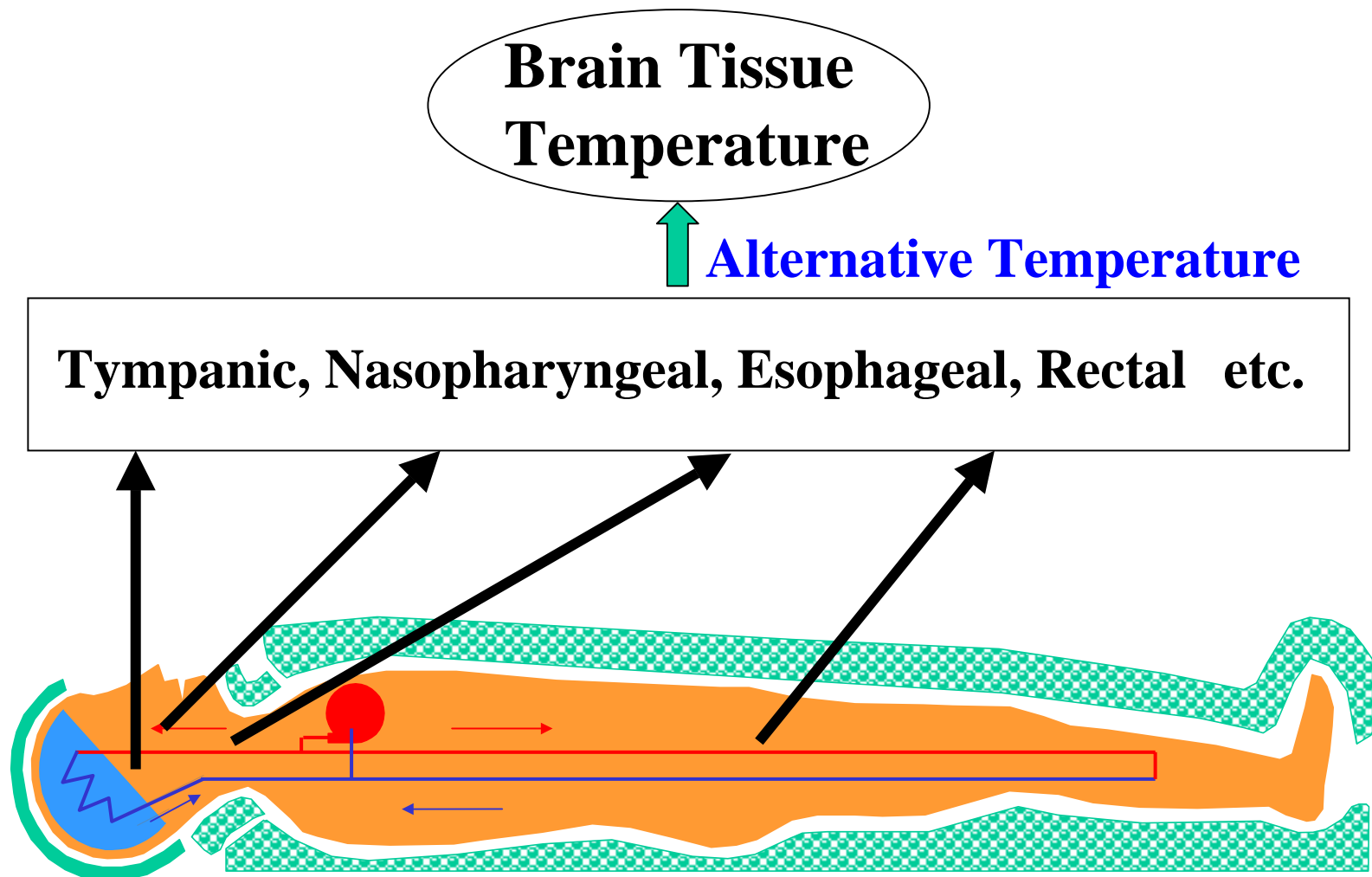

# Automatic Control of Brain Temperature

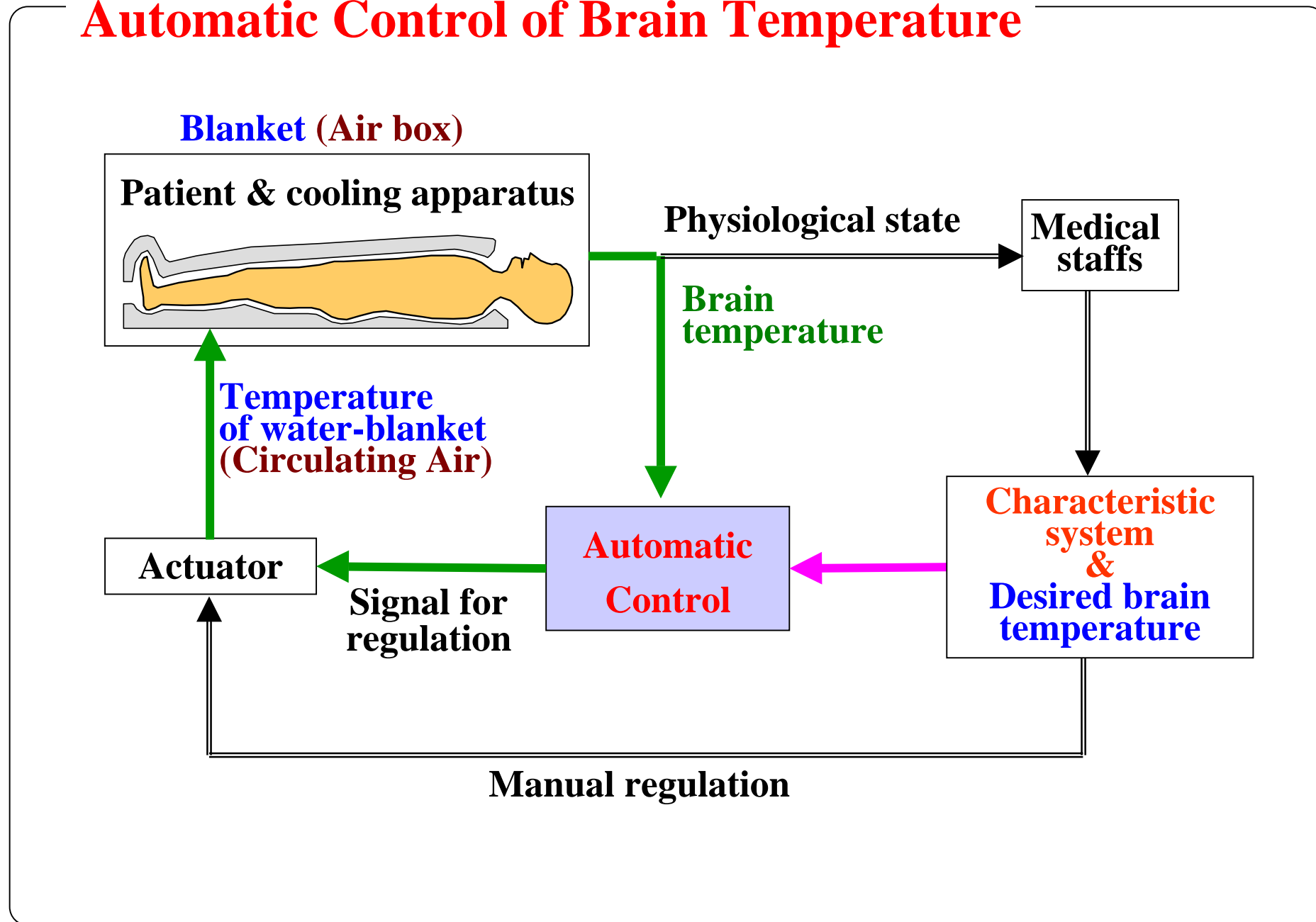

# Damage of brain cell caused by energy insufficiency

## Symptom

Head injury

Neonatal asphyxia

Cerebrovascular disorder

Insufficiency of heart & lung

Cerebral Ischemia & Energy Insufficiency

## Brain cell damage

Precocious nerve cell damage

Delayed nerve cell damage

# **Damage of brain cells caused by hypersecretion of neurohormone**

**Hypothalamus-Pituitary-Adrenal System Hyperfunction**

**Excessive secretion of catecholamines**

**Cardiac hypofunction due to disorder of heart muscle in diastolic phase  
Insulin resistance hyperglycemia due to glycogenolysis  
Decrement of erythrocyte DPG      disorder of O<sub>2</sub> – dissociation from Hb**

**Recovery obstruction of trauma brain cell**

# **Protection of brain cells by brain hypothermia**

## **Suppression of Damage caused by Energy insufficiency**

**Improvement homeostasis of  $\text{Ca}^{2+}$**

**Suppression of oxidation by free radicals**

**Activation of antiapoptosis substance**

**Suppression of dopamine A10 neural groups**

## **Suppression of Hyperfunction of Endocrine system**

**Suppression of hypersecretion of catecholamines**

# **Damage of brain cells caused by hypothermia less than 32**

---

**Energy metabolic insufficiency  
imperfect circulation**

- **Shortage of ATP for brain cell recovery**
- **Decrement of brain blood flow amount**

**Deprivation of Recovering damaged brain cells**

## Trade off in Hypothermia

Protection of  
brain Tissue

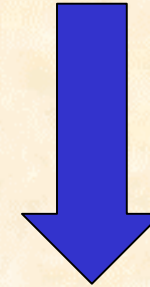

Biological reaction

Demerit in hypothermia

Necessity of precise and accurate  
control of brain temperature !

# Mild Hypothermia

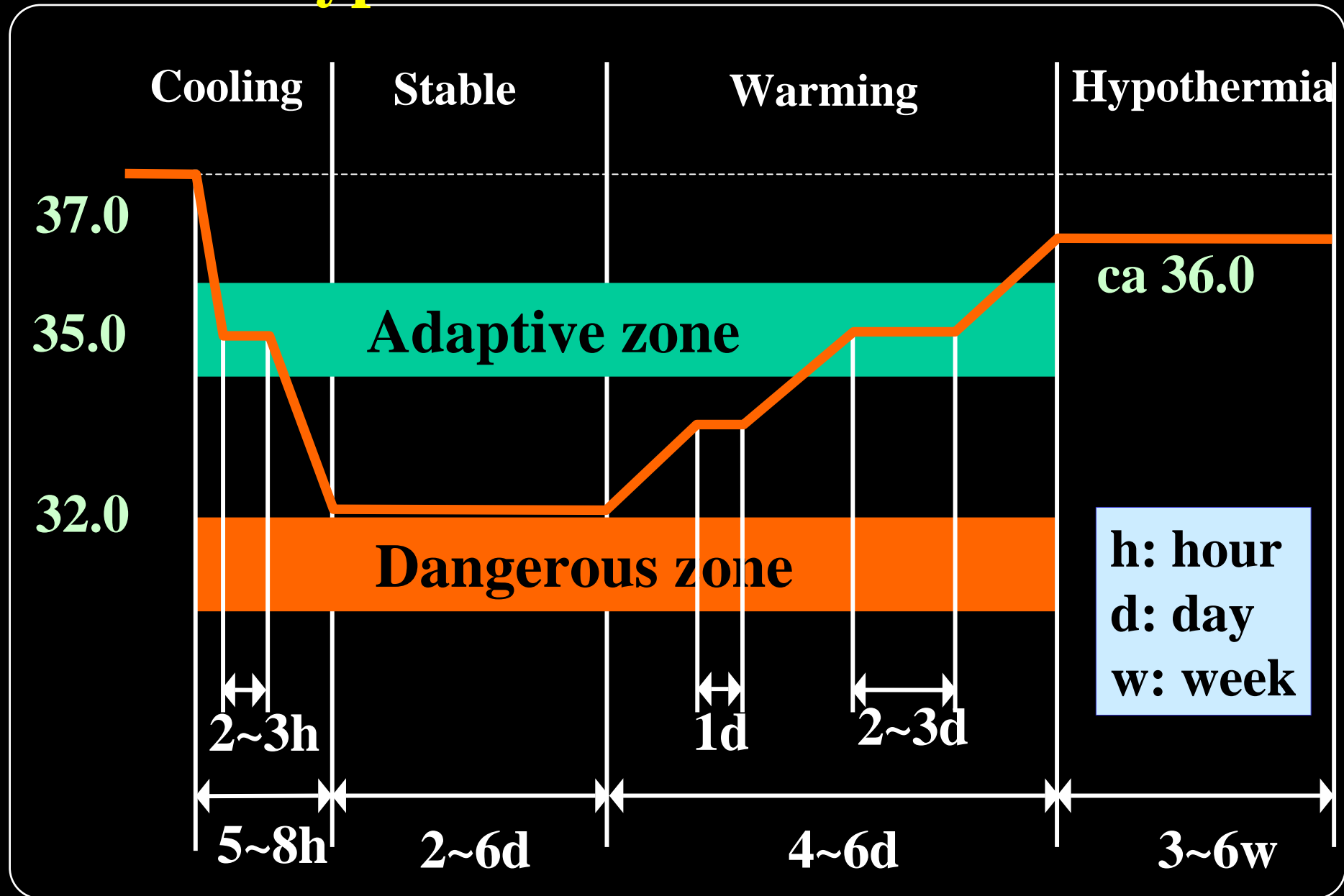

# Concept of Adaptive Control Engineering

Different regulation

Various kinds of medical treatment

Change in external environment

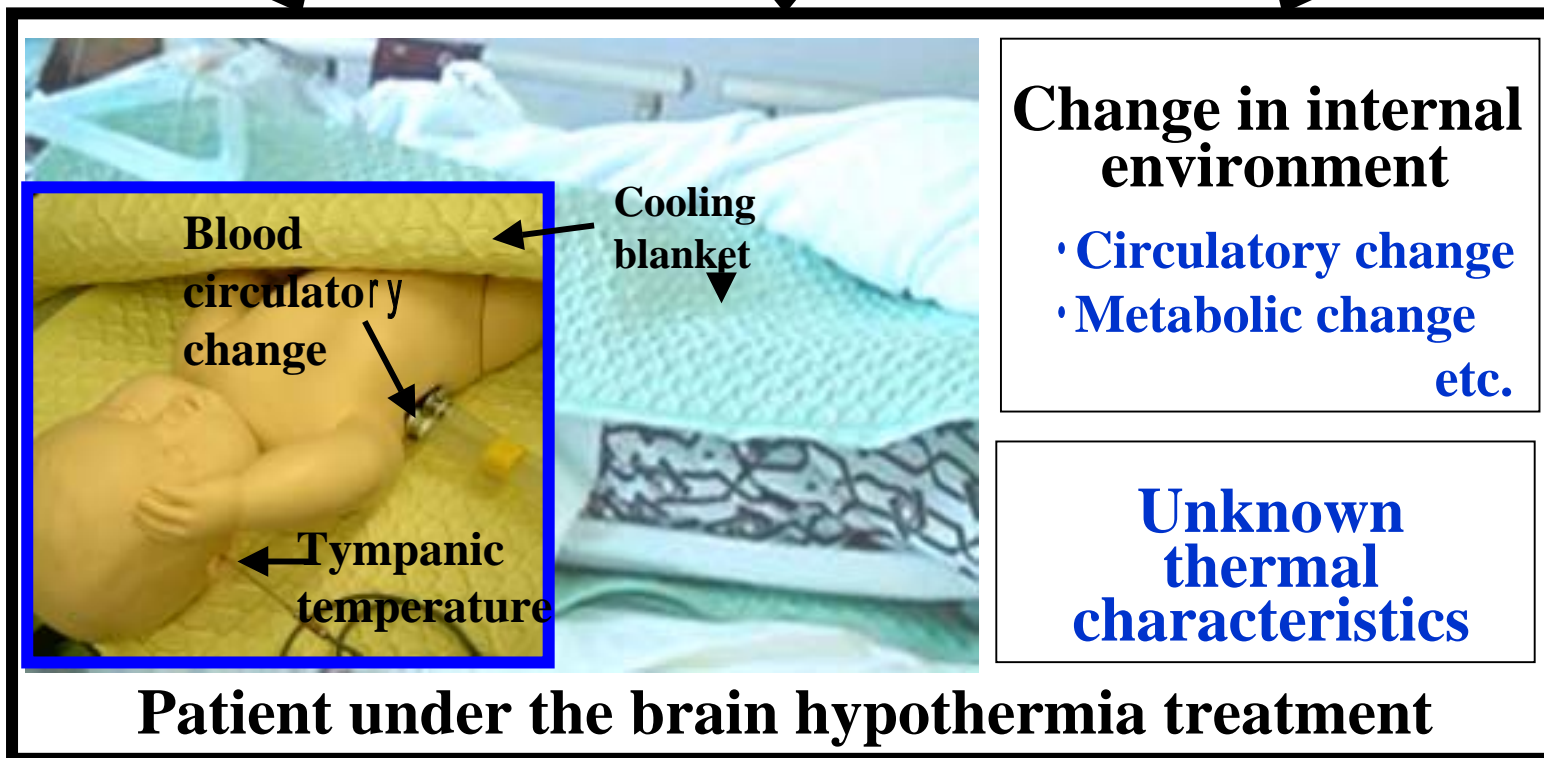

Adaptive control

**Realization of desired brain temperature**

# Overview of Experimental Equipment for infantile brain hypothermia

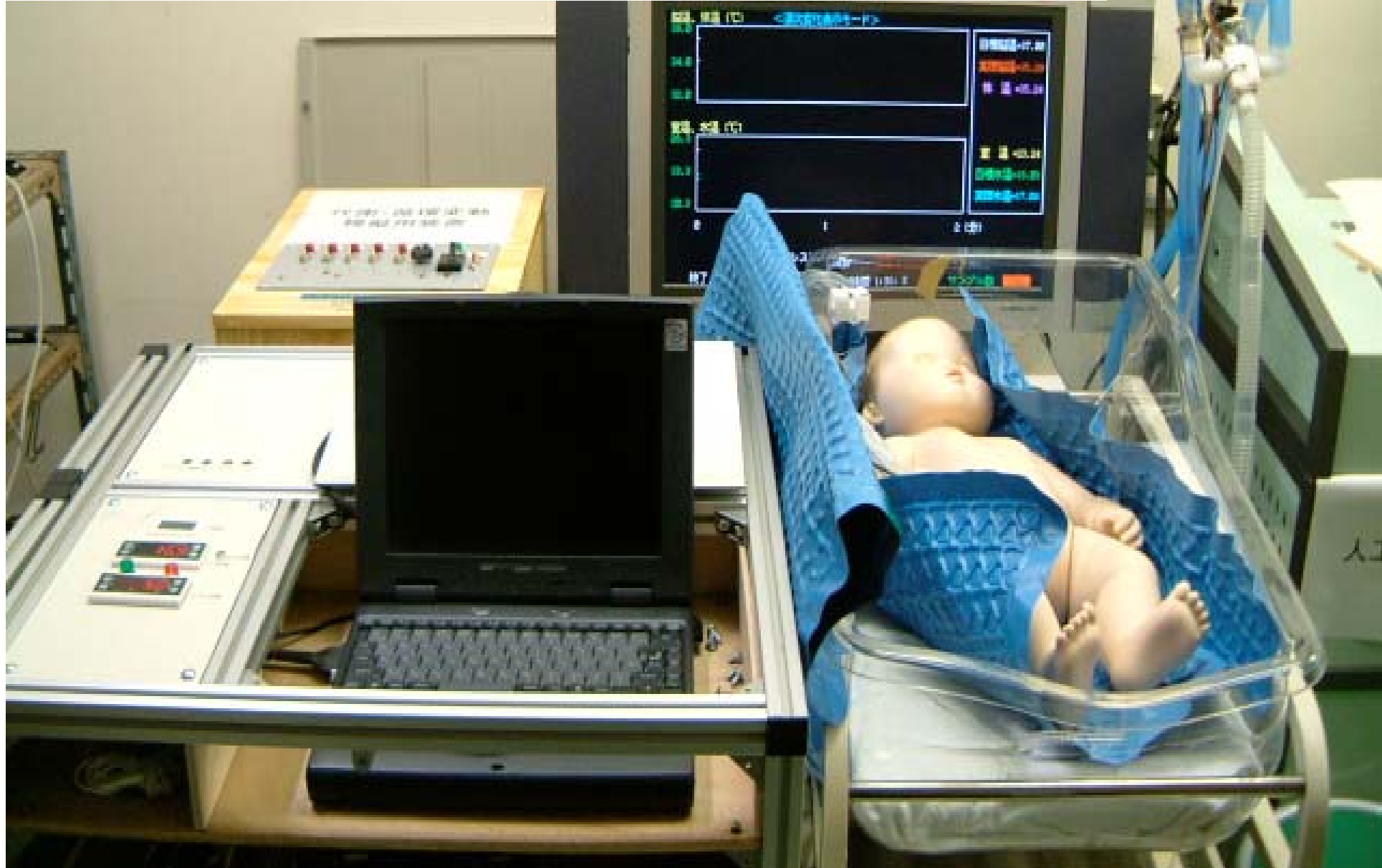

# Outlook of cooling system for infantile brain hypothermia



# Automatic control system of brain temperature

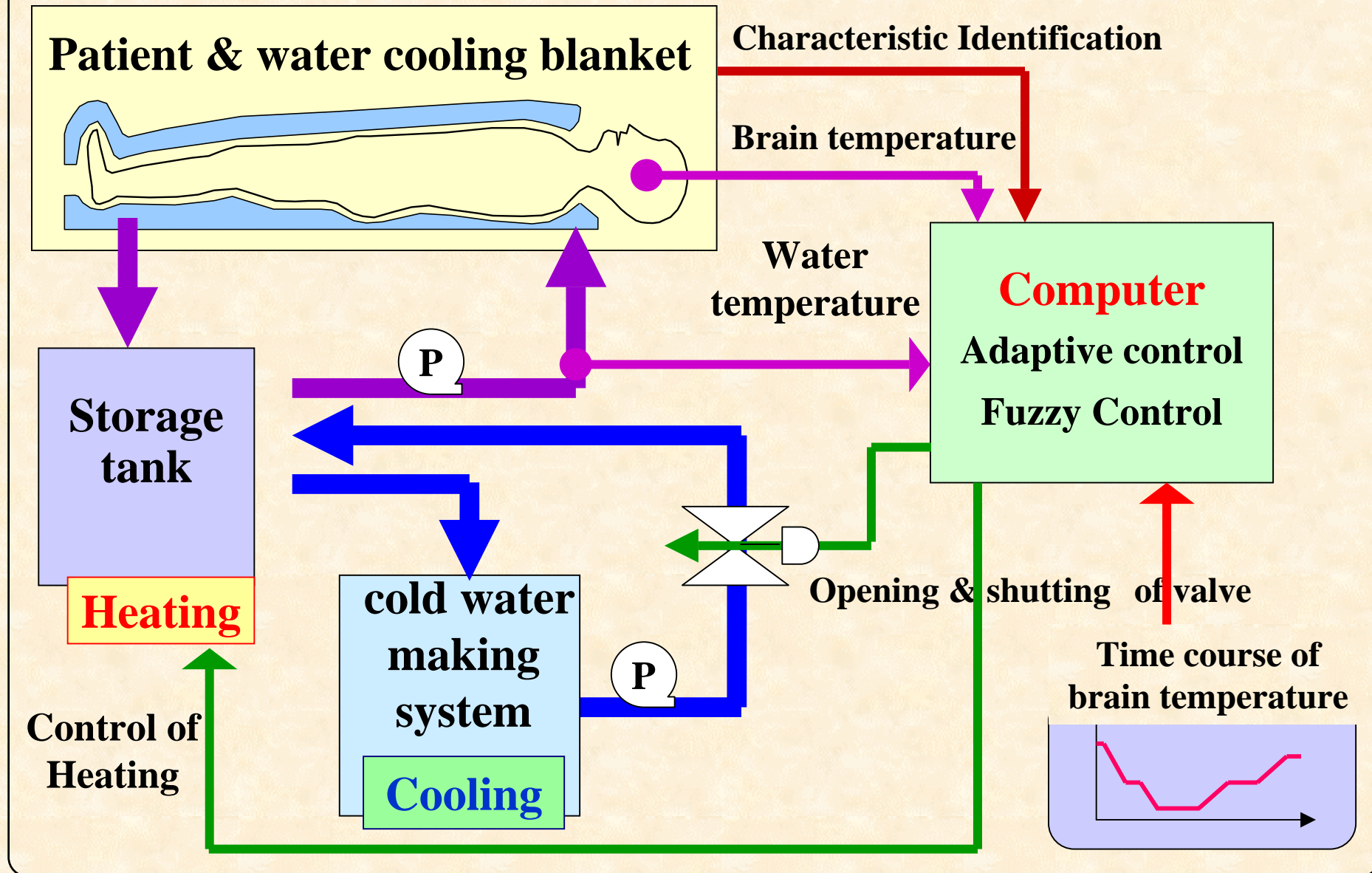

# Influential Factors on Brain Temperature Control

**Environmental change**

**Room temperature , Direct sunshine and Covering of Blanket**

affection

**Control of brain temperature**

affection

**Patient's state change**

**Blood amount in circulation  
Metabolic rate (esp. in brain)**

# (1) Optimal · Adaptive Control

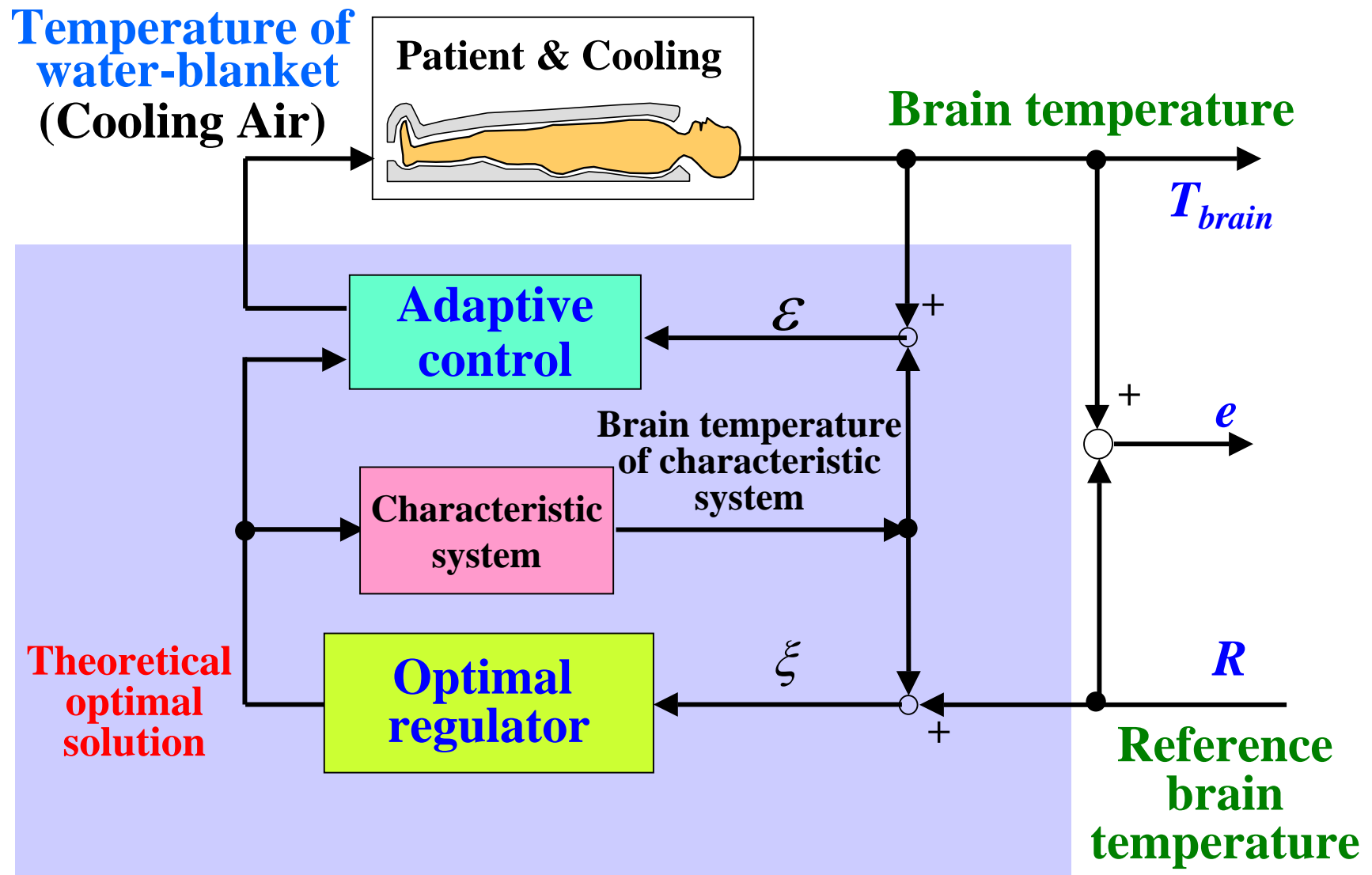

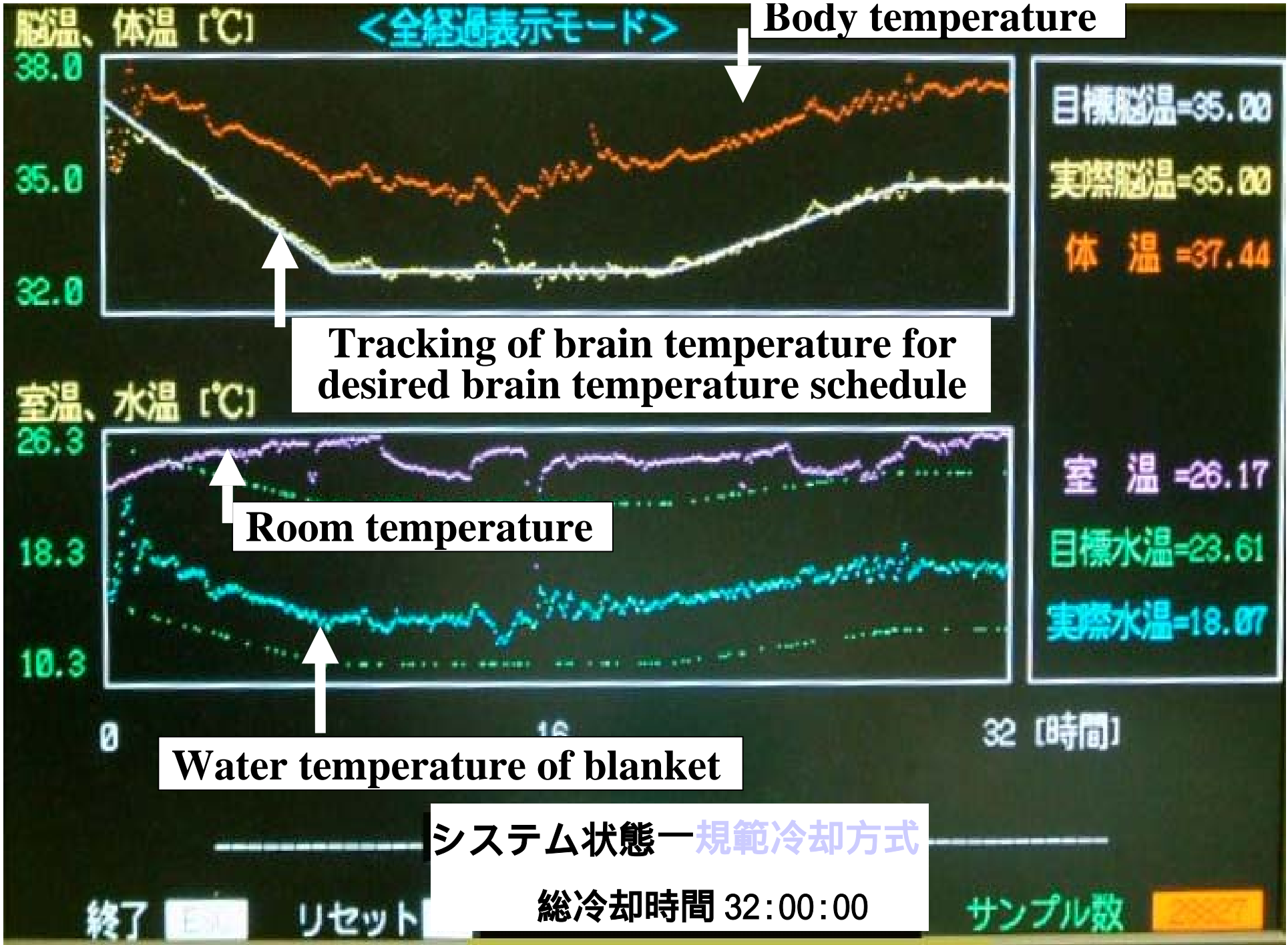

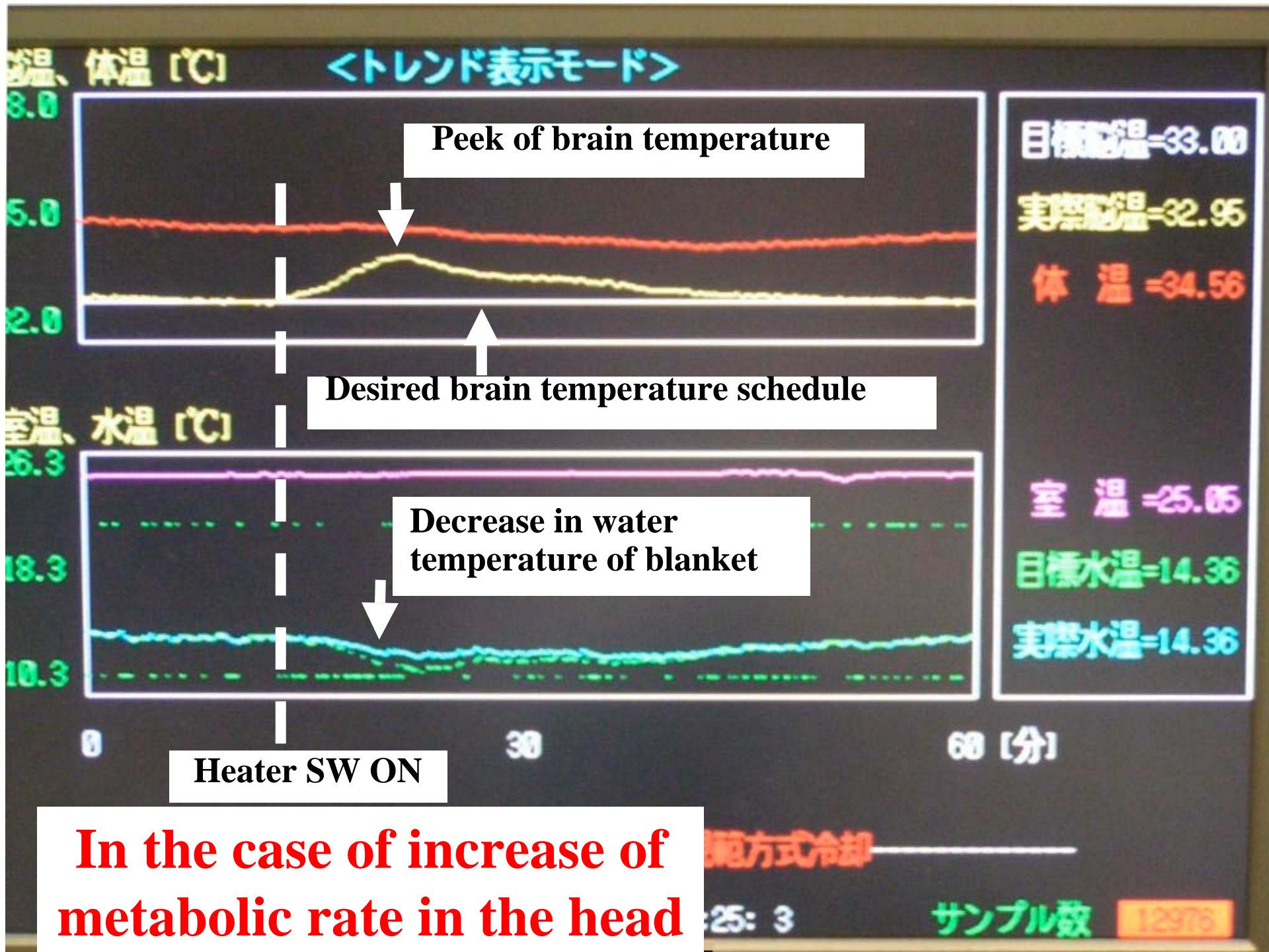

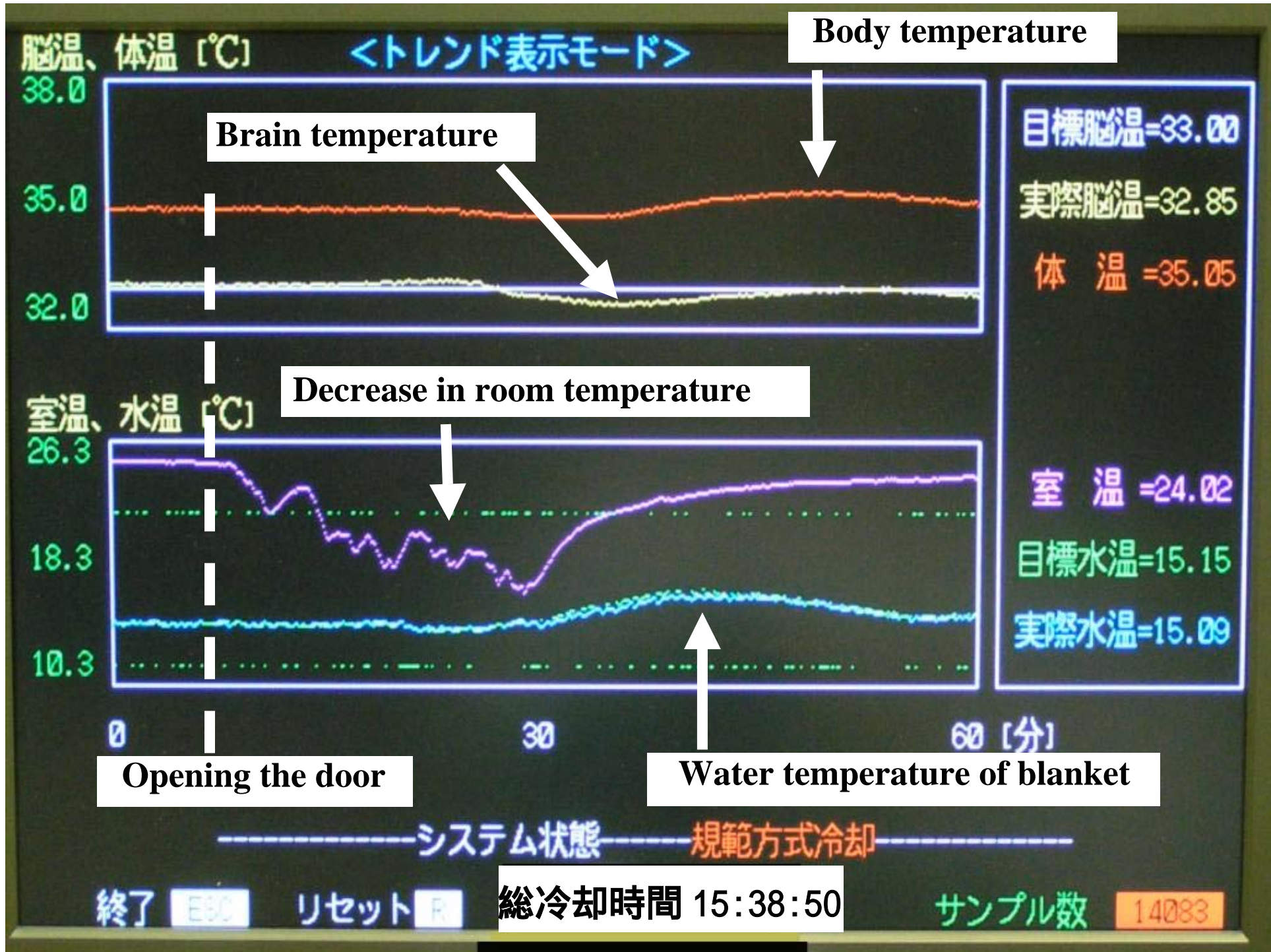

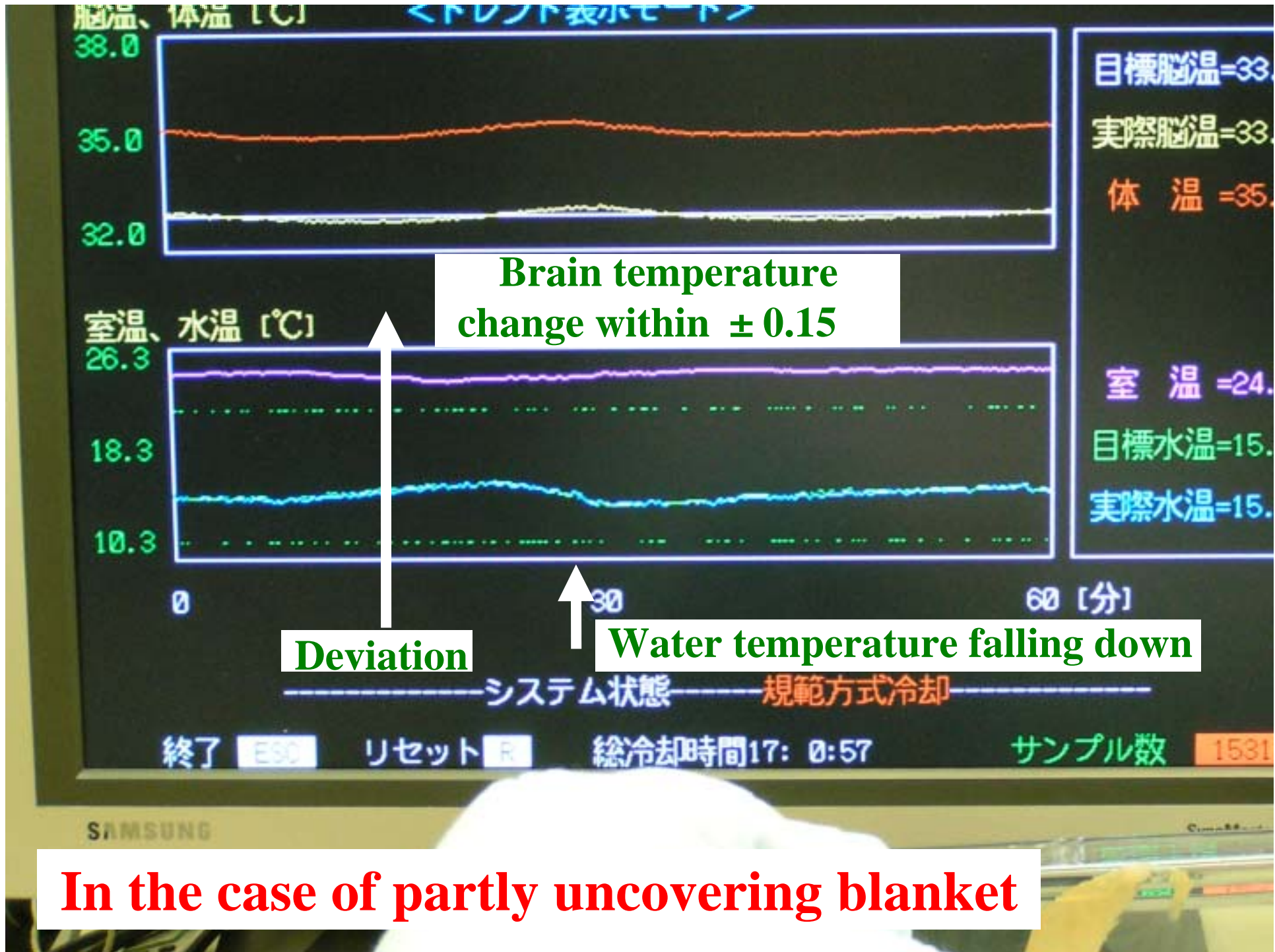

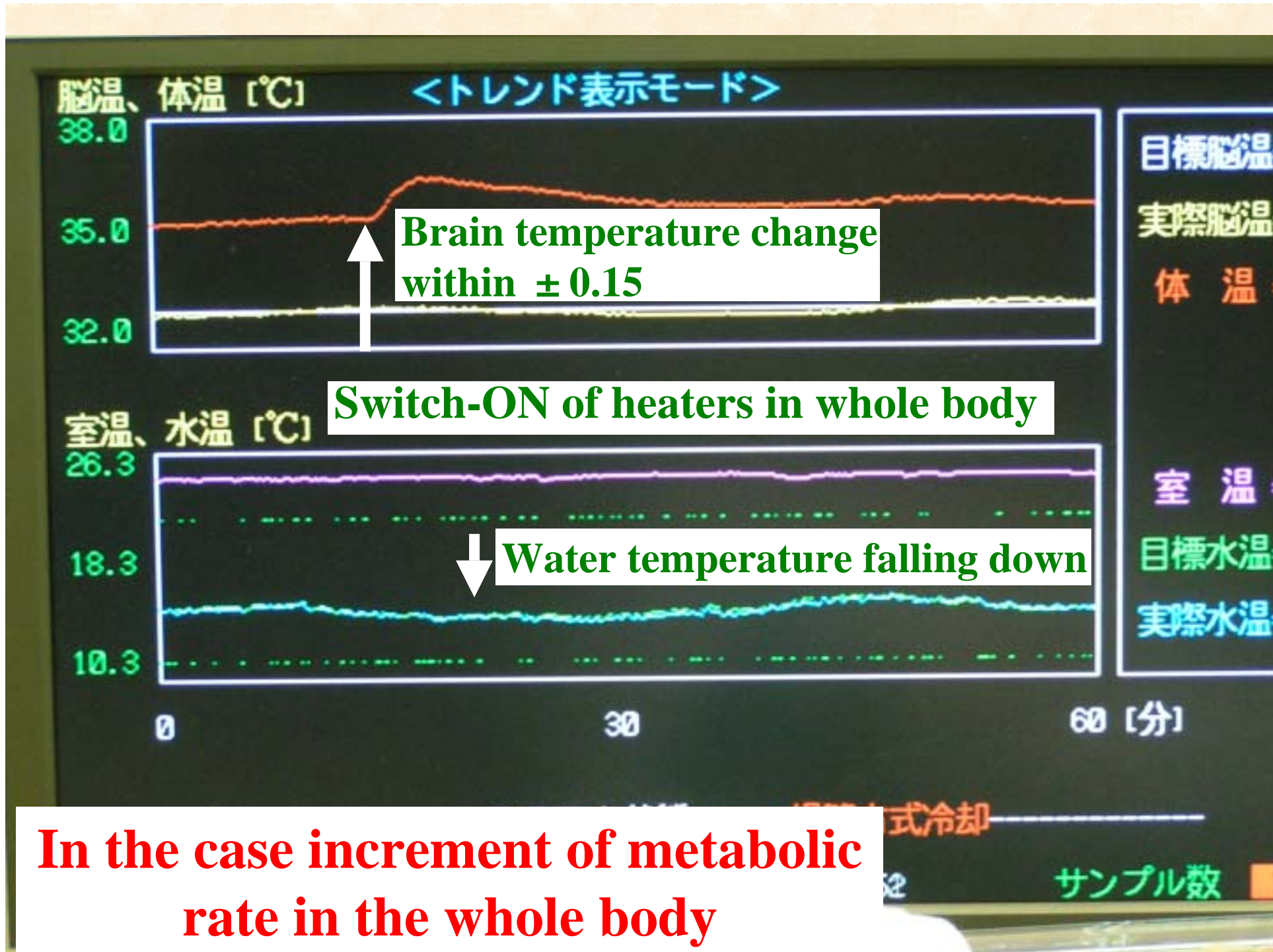

## (2) Introduction of Fuzzy method

**Optimal-adaptive control** : not always match with  
commonly understood knowledge  
of medical staffs

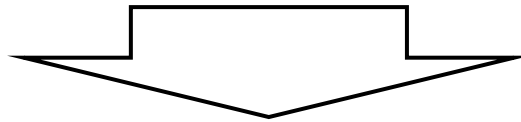

Control system based on **clinical experience**

➡ Human friendly control of brain temperature

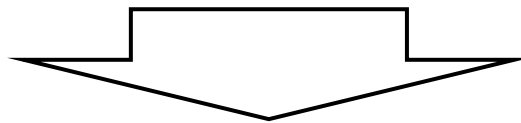

Its realization? ➡ **Fuzzy Control**

# Fuzzy Control System of Brain Temperature

## Rational Control According to Common Characteristics of Patients

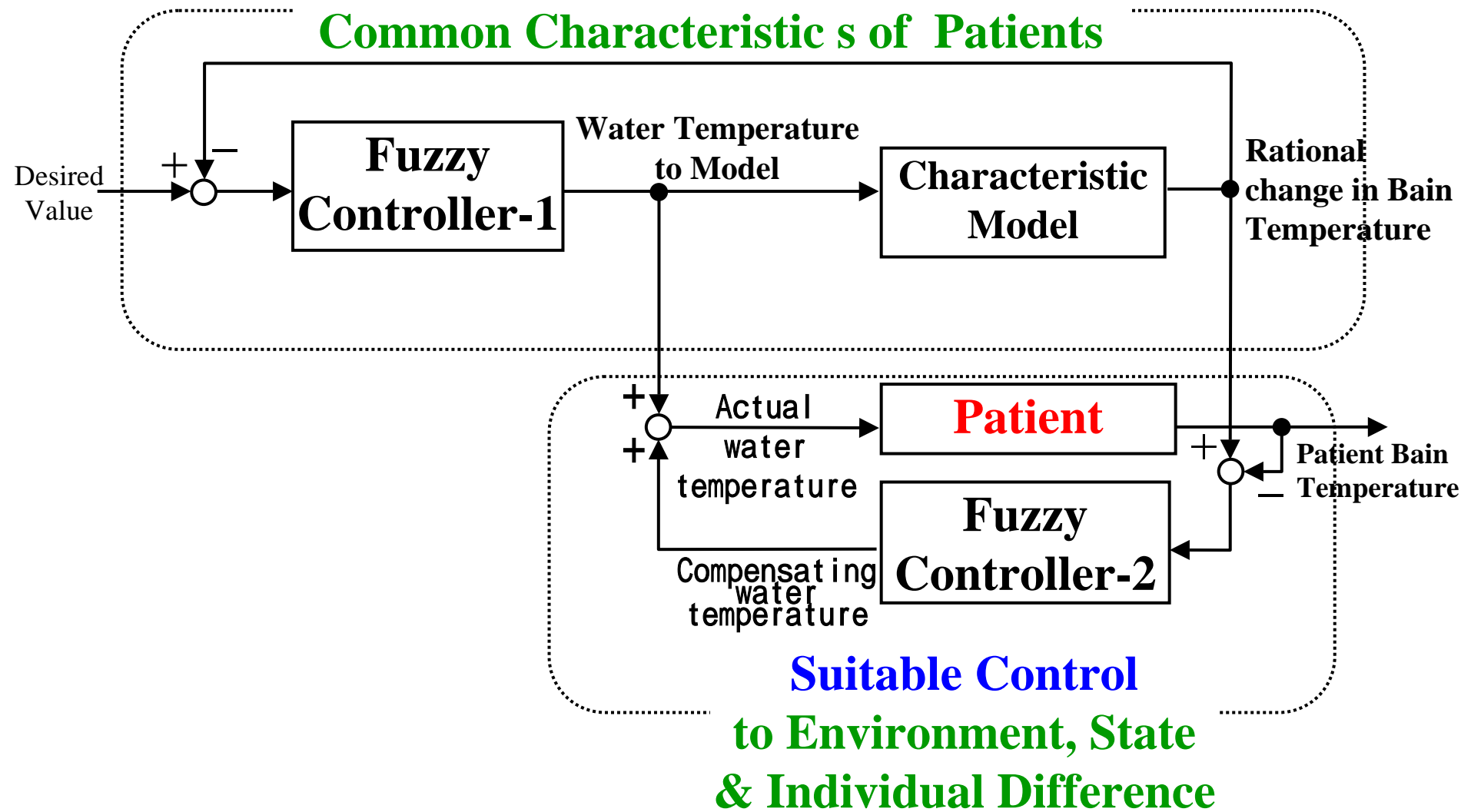

# Membership Functions and Fuzzy Rule

For fuzzy controller-1

*The antecedent*

		$e(k)$		
		PB	ZO	NB
<i>The antecedent</i>	$\Delta u(k)$	PB	PS	ZO
		ZO	ZO	NS
		NB	NS	NB
		<i>The consequent</i>		

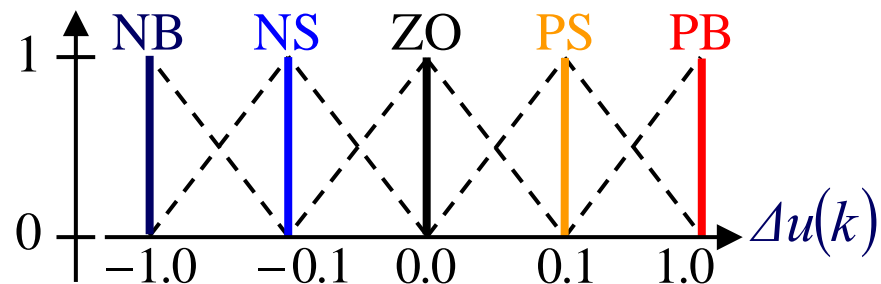
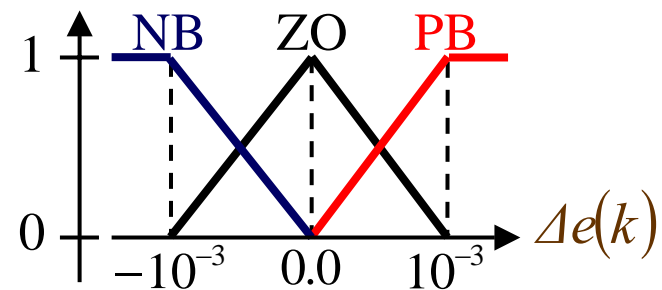
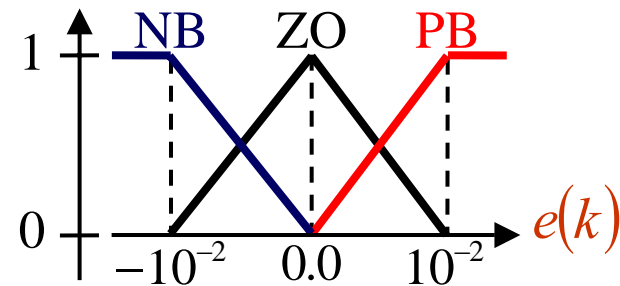

# Membership Functions and Fuzzy Rule

For fuzzy controller-2

*The antecedent*

		$\varepsilon(k)$							
		PB	PM	PS	ZO	NS	NM	NB	
<i>The antecedent</i>	$\Delta v(k)$	PB	PVB	PVB	PS	ZO	PVB	PVB	NM
	$\Delta \varepsilon(k)$	PS	PVB	PVB	PS	ZO	PM	PB	NB
	$\Delta \varepsilon(k)$	ZO	PVB	ZO	ZO	ZO	ZO	ZO	NVB
	$\Delta \varepsilon(k)$	NS	PB	NB	NM	ZO	NS	NVB	NVB
	$\Delta \varepsilon(k)$	NB	PM	NVB	NVB	ZO	NS	NVB	NVB
		<i>The consequent</i>							

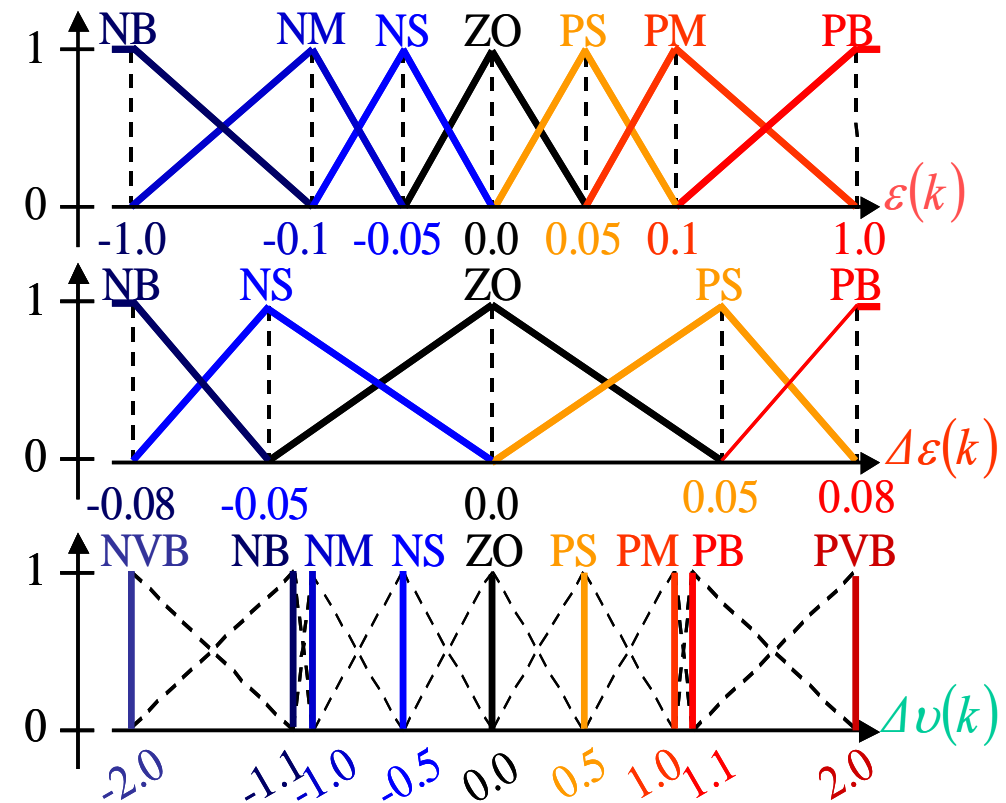

# Experimental Result during Cooling and Stable Period

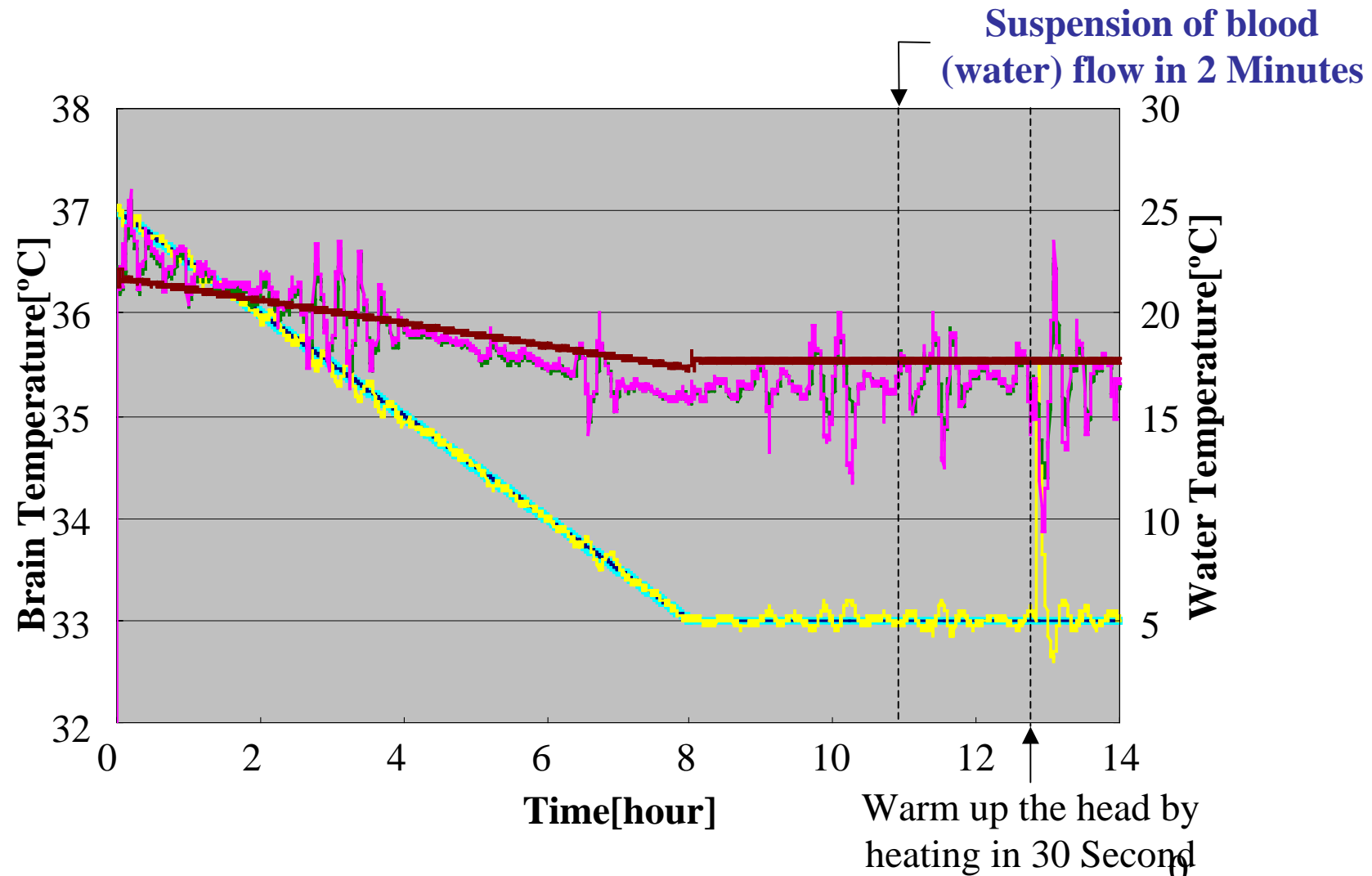

<span style="color: cyan;">—</span> Desired Brain Temperature	<span style="color: brown;">—</span> Water Temp. to Characteristic Model
<span style="color: blue;">—</span> Brain Temp.of Characteristic Model	<span style="color: magenta;">—</span> Objective Water Temp. to Mannequin
<span style="color: yellow;">—</span> Brain Temp. of Mannequin	<span style="color: green;">—</span> Actual Water Temp.

# Experimental result

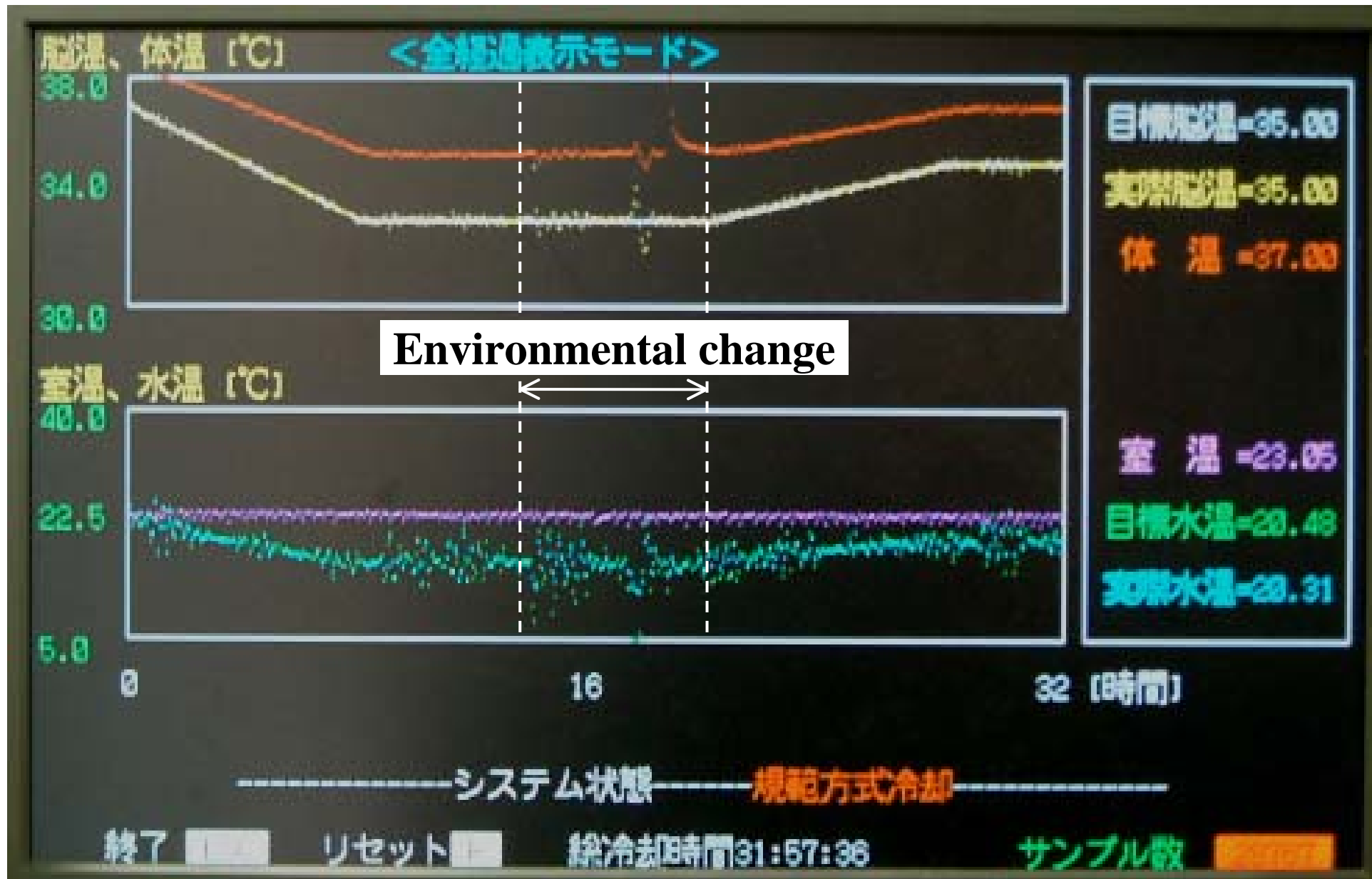

# Change of metabolism in brain ( 2 )

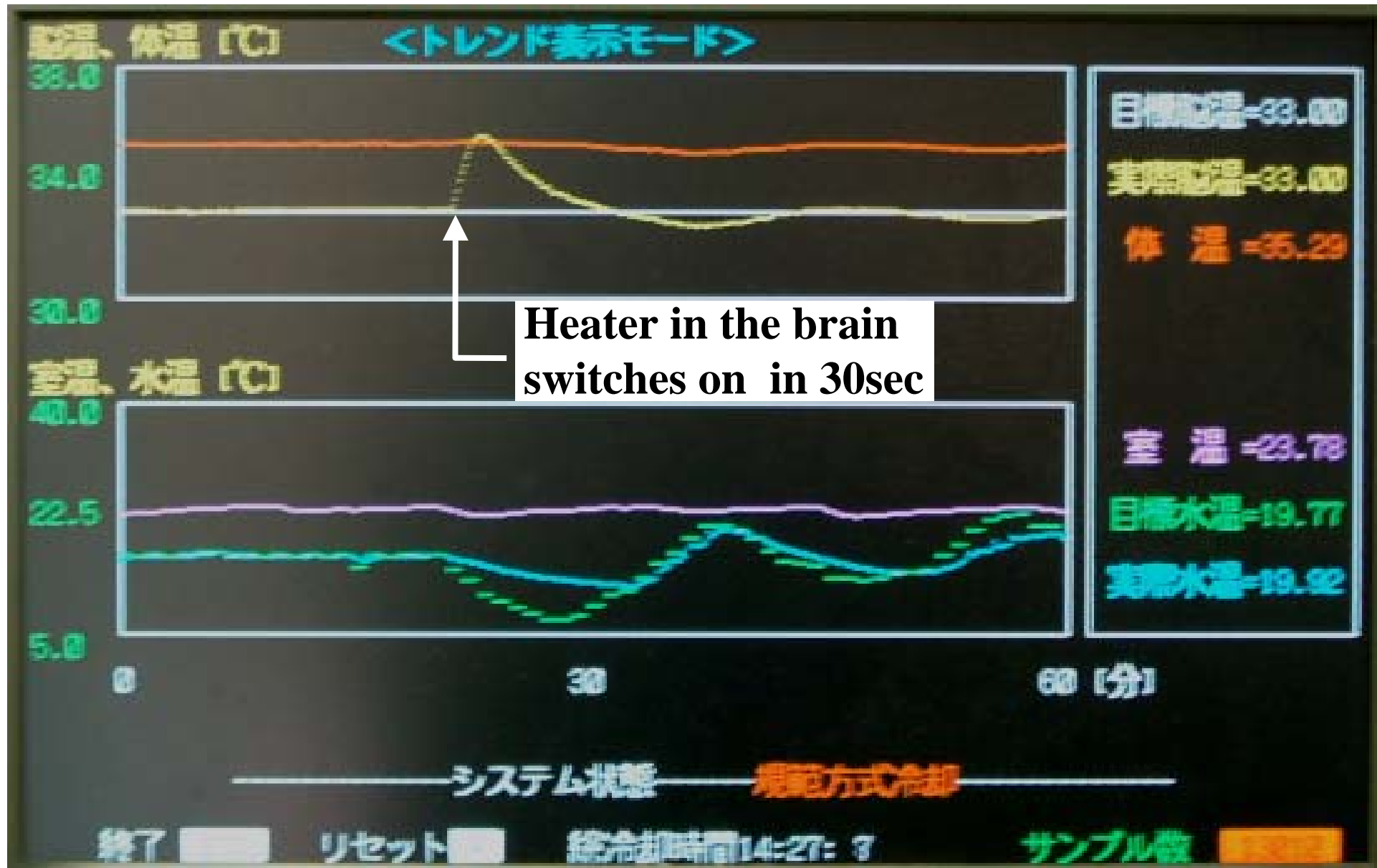

# **Clinical Control System of Brain Temperature**

**Adaptive Control & Fuzzy Control**



**Apparatus for heating and cooling of water**



**Reservoir for warm water**



**Reservoir for warm water**

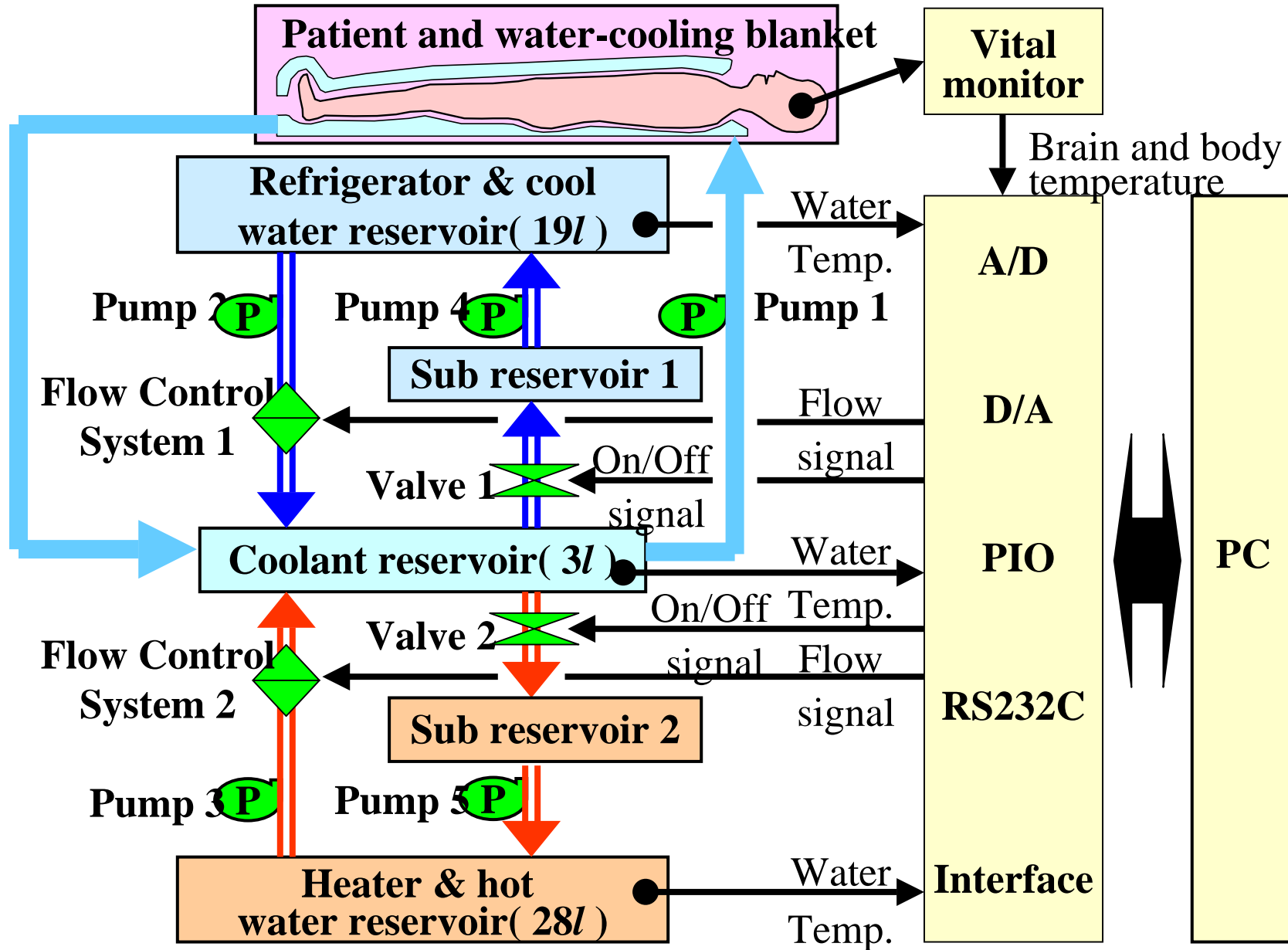

**Control System of Brain Temperature**

脳温、体温 (°C)

<全経過表示モード>

39.6

36.6

33.6

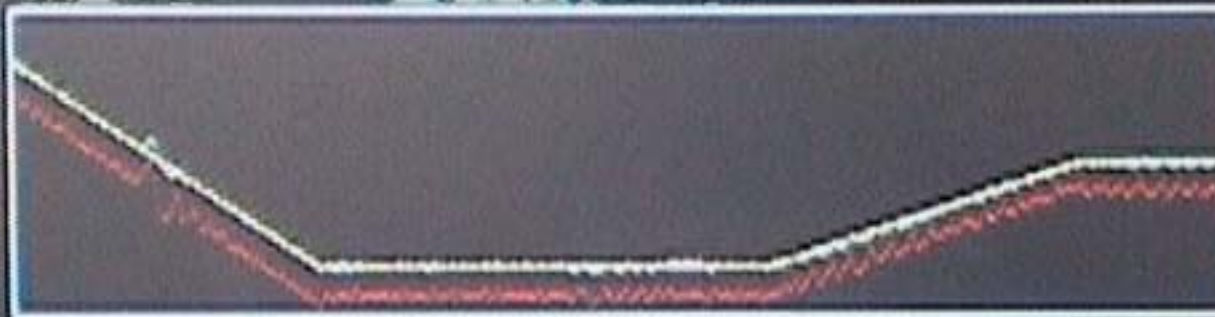

目標脳温=38.57

実際脳温=36.51

体温=36.87

冷水温度=4.05

温水温度=41.71

室温=23.00

目標水温=42.31

冷却水温=31.29

室温、水温 (°C)

36.2

28.2

20.2



0

16

32 (時間)

--- 脳温適応制御 ---

<温水混合中

> 装置内温=30.08

終了

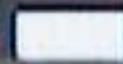

リセット



総冷却時間32: 3: 0

サンプル数

115376

脳温、体温 [°C]

<全経過表示モード>

39.5

36.5

33.5



目標脳温=36.52

実際脳温=36.54

体温=36.01

冷水温度=5.44

温水温度=44.78

室温=25.45

目標水温=25.62

冷却水温=25.73

室温、水温 [°C]

33.3

25.3

17.3

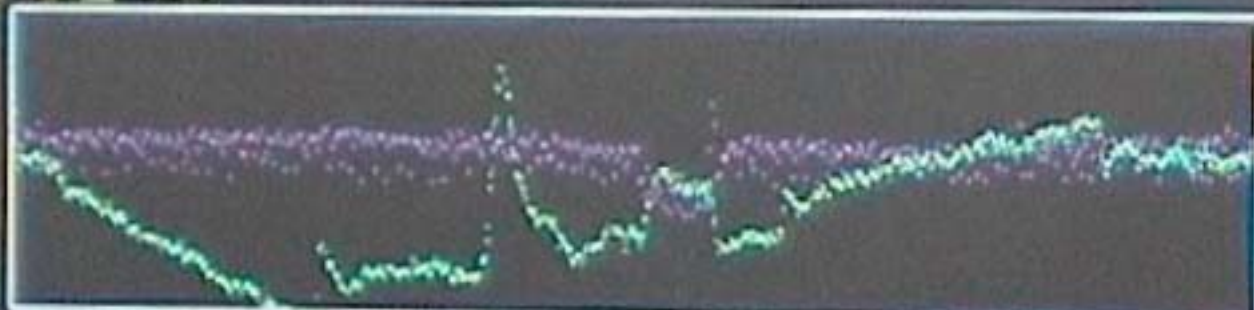

0

16

32 [時間]

ファジィ制御

<温冷水混合なし>

装置内温=27.75

終了

リセット

総冷却時間31:54:42

サンプル数

114881



**Brain Hypothermia Treatment ( image )**



**Experimental brain hypothermia 5-channel water cooling suits ( image )**

# Control of Brain Temperature by Air-Cooling System

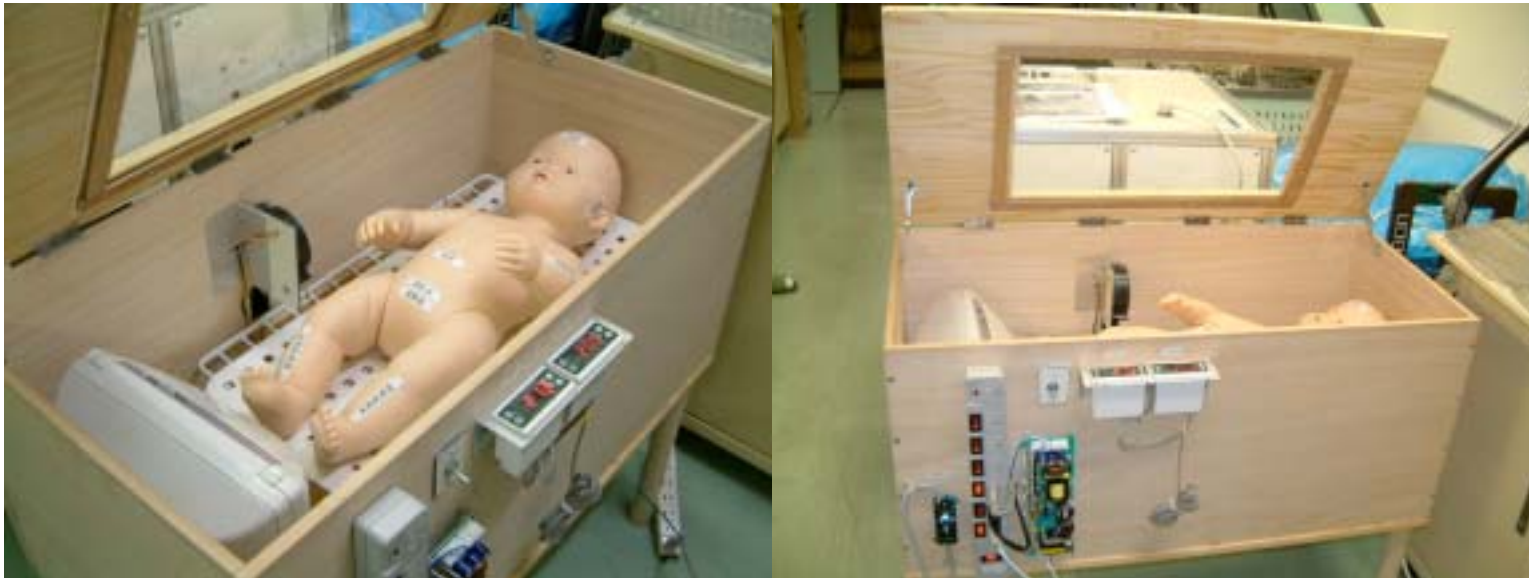

# Air-cooling Incubating System

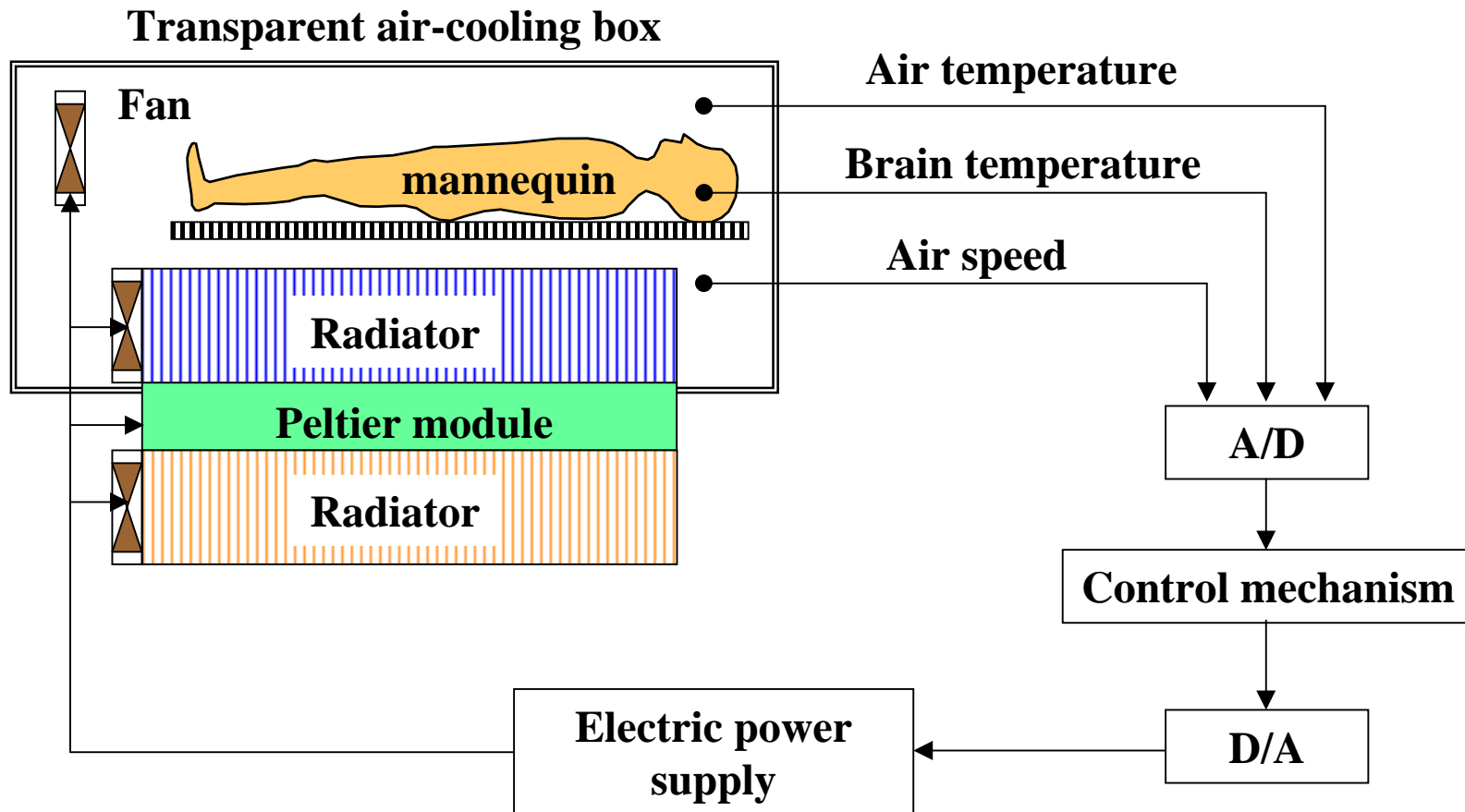

**Prospective**

**Administration system of  
whole physiological state**

**Parallel measuring system of  
physiological data**

**Control system of depth of anesthesia**

# Comprehensive Control System

**Manual control of  
whole body**

**Overall View of Physical Constitution  
Monitoring · Decision · Action  
Treatment with Experience & Intuition**

**Information  
Execution**

**Communication**

**Examination  
Order**

**Supplementary Administrative System for  
monitoring constitutional physiology  
Routine work treatment  
Treatment based on calculation  
of systematic description**

**Automatic  
Control**

**Integrated  
Monitoring**

# Comprehensive Monitoring of Physiological State

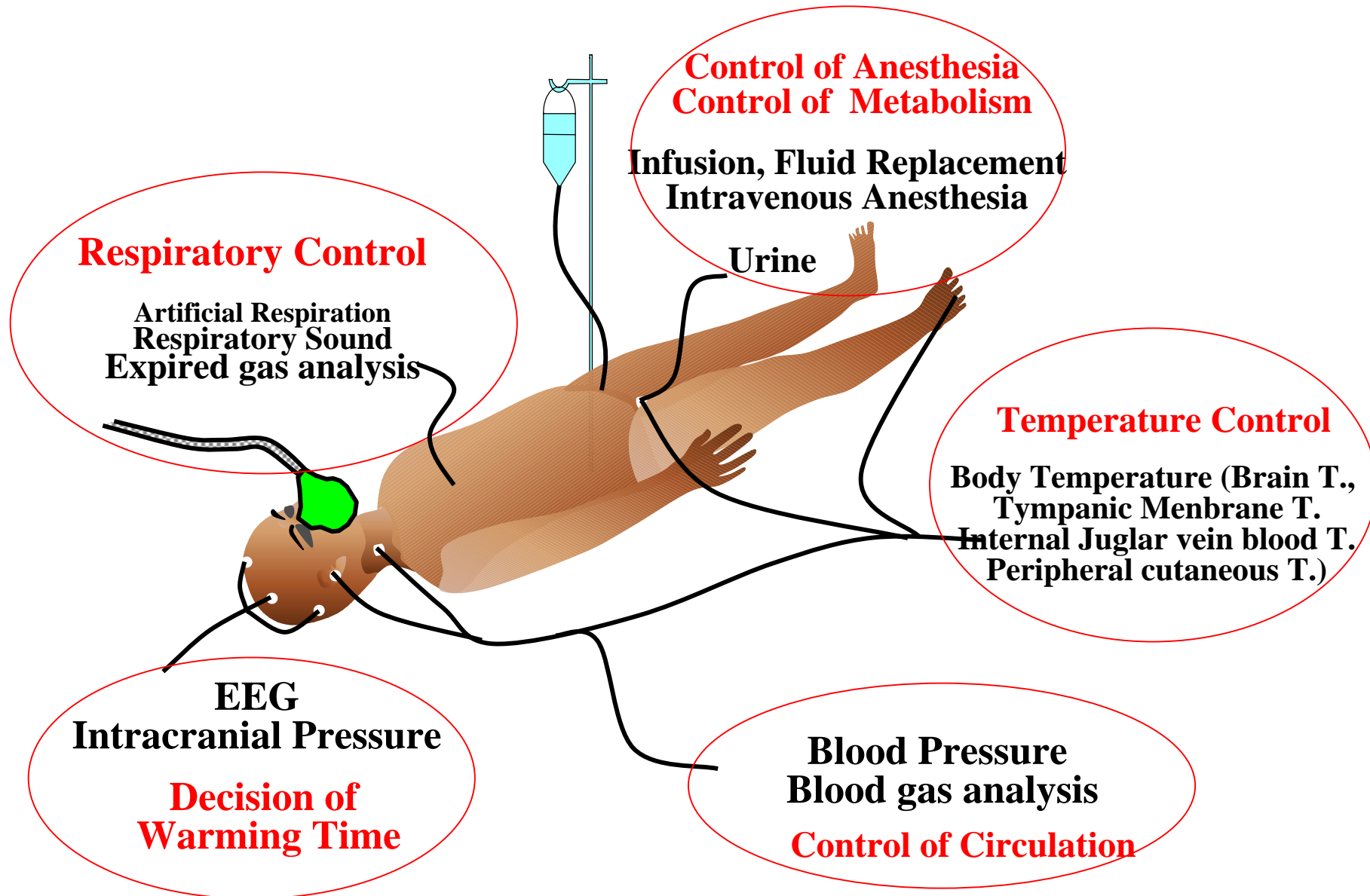

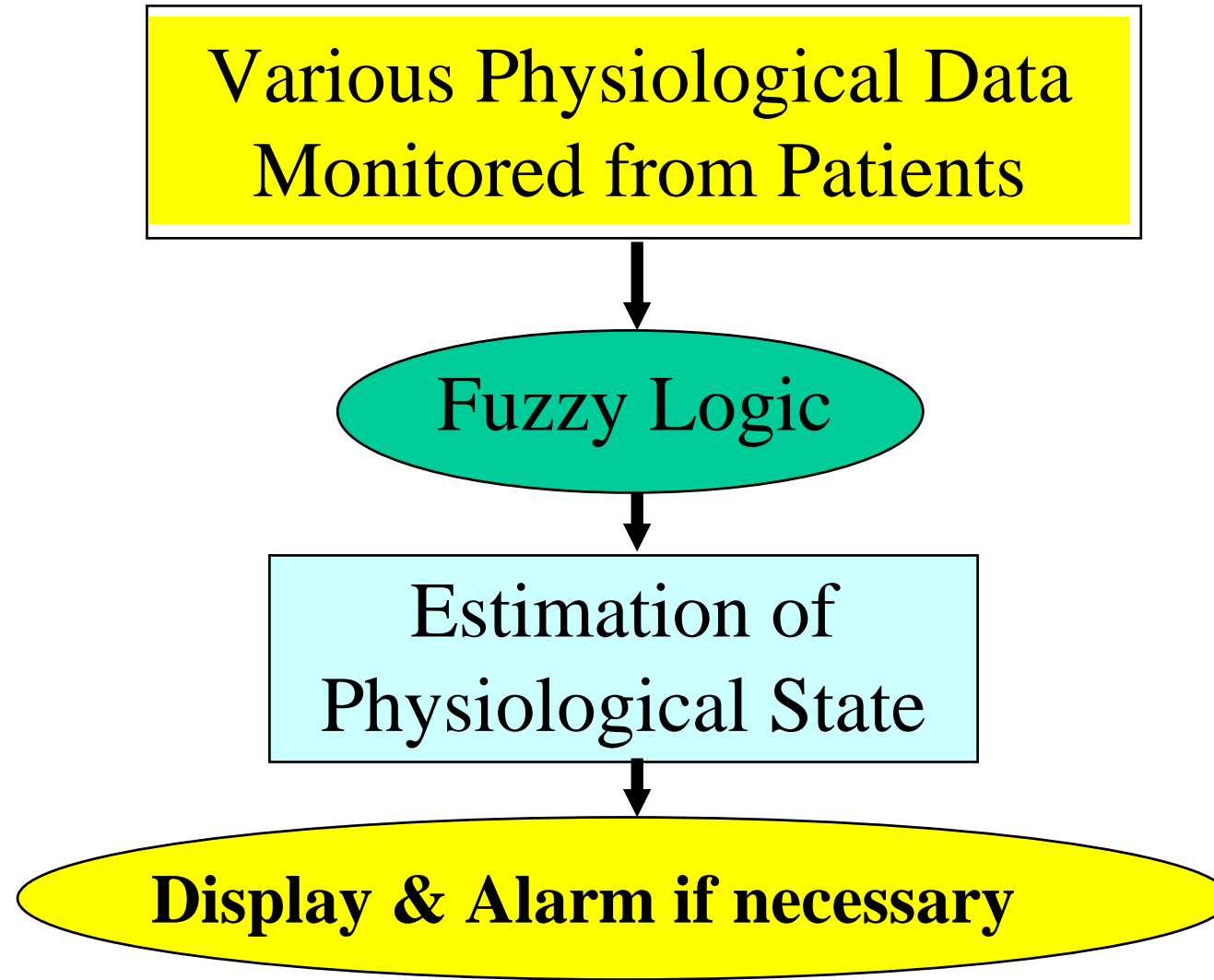

## **Evaluation and Alarming System**



**Acquisition system of various kinds of physiological data**



**Various physiological data acquisition and information processing**

# **Cooperative teams for clinical test**

**Tokyo Medical and Dental University**

**Integrated pulmonology, Neurosurgery,  
Anesthesiology, Critical care medicine**

**National Hospital Tokyo Disaster Medical Center**

**Critical care center, Neurosurgery**